

THK



NEW

Caged Ball LM Guide

Ultra-Heavy Load, High Rigidity Type
Improved Dust Control Performance
Optimized for Machine Tools

SVR/SVS

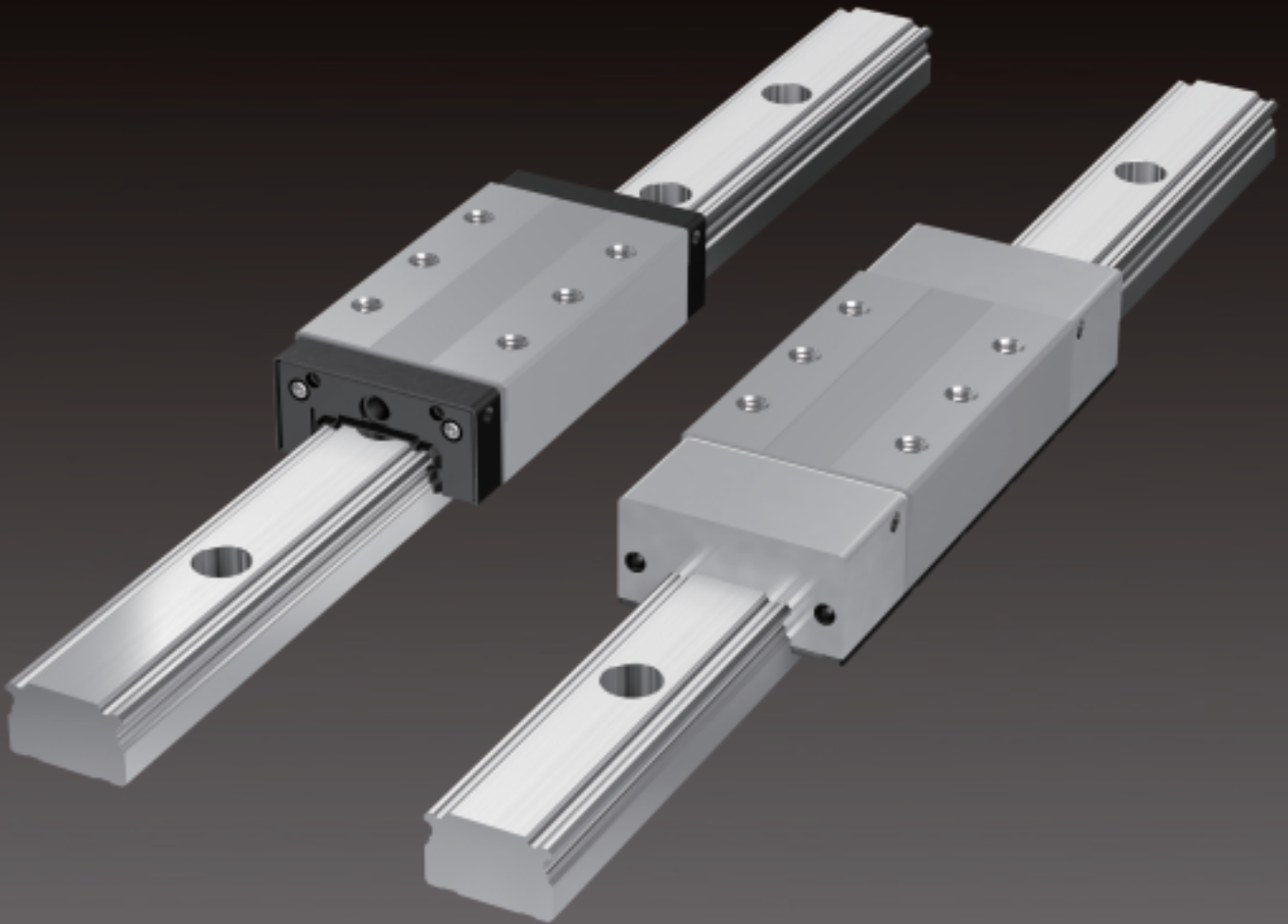

For details, visit THK at www.thk.com
*Product information is updated regularly on the THK website.

THK CO., LTD.
TOKYO, JAPAN

CATALOG No.356-2E

Caged Ball LM Guide

Mechanical motion of a machine is made up of two motions; Rotational motion and Linear motion. And these motions of machine has evolved from "sliding" to "rolling."

"Rolling" in the rotational motion was realized with the advent of the ball bearing more than 100 years ago.

Since then, the ball bearing has evolved from a full-ball type in the early years into a caged-ball type, which enables the balls to be evenly aligned without being in contact with each other, resulting in drastic improvement of the performance.

Concerning the linear motion, "LM Guide," a linear motion guide that THK developed and commercialized in 1972, was adopted in industrial equipment and various other machinery as an innovative product that realizes "rolling."

Since "LM Guide" evolved from a full-ball type into "Caged-Ball LM Guide" in 1996, its performance has also drastically been improved and the areas of its application has been broadened to various industrial fields.

Feature of the Caged Ball LM Guide

- Long Service Life and Long-term Maintenance-free Operation
- Superbly High Speed
- Low Noise, Acceptable Running Sound
- Smooth Motion
- Low Dust Generation

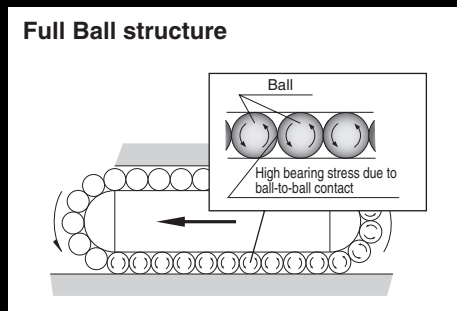

- Adjacent balls are in point contact with each other. As a result, the surface pressure of the contact region is high and the oil film easily breaks.
- Wear occurs due to friction between adjacent balls.
- Collision noise is produced due to contact between adjacent balls.
- the service life is short for the above reasons.

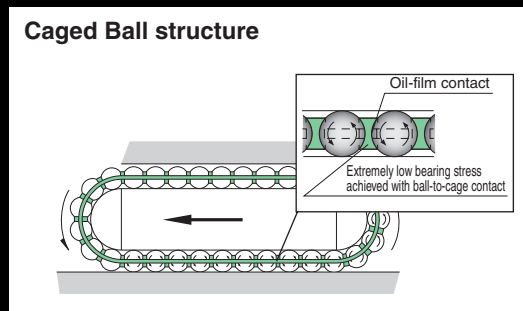

- Since the friction between adjacent balls is eliminated,
- The oil film does not easily break.
 - Friction wear is reduced.
 - Heat generation during high-speed operation is suppressed.
 - Degradation of the lubricant is suppressed.
 - Collision noise is suppressed.
 - Balls move smoothly because they are evenly aligned.
 - Lubrication condition is improved by the ball cage.
 - The service life is longer for the above reasons.

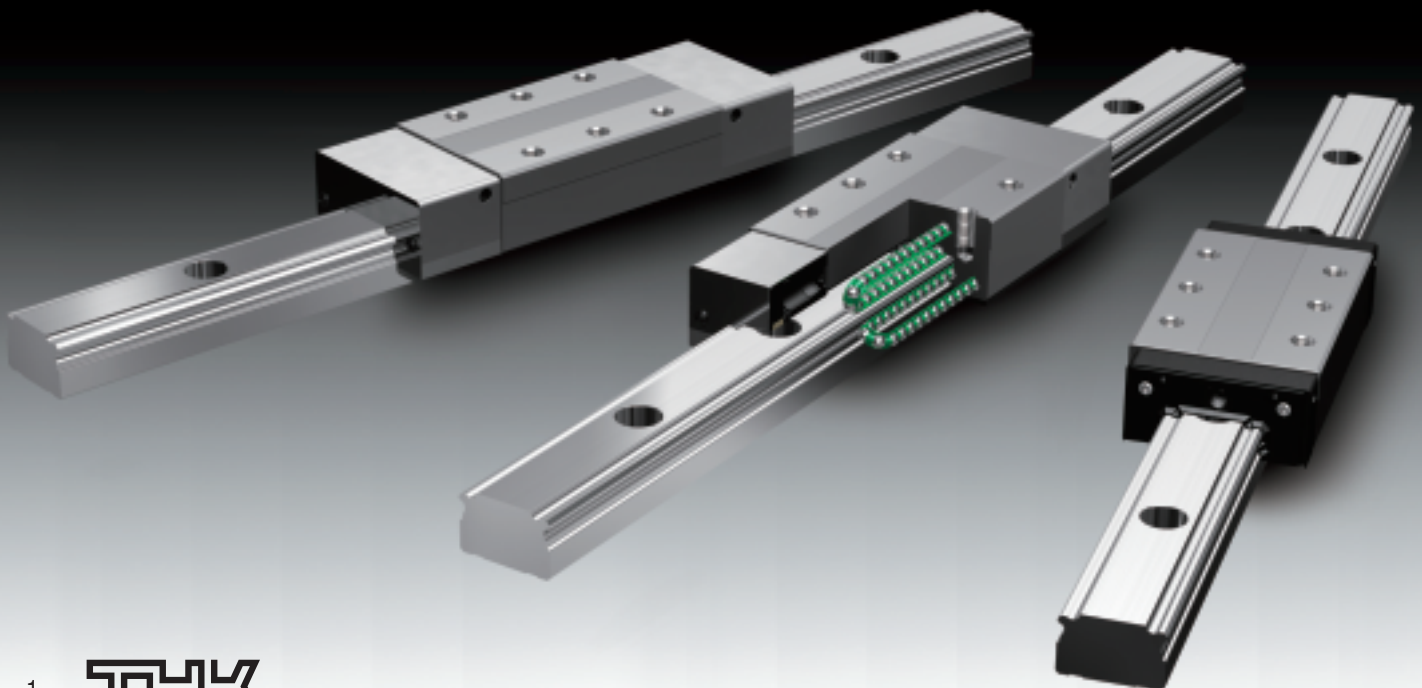

Ultra-Heavy Load, High Rigidity Type
Improved Dust Control Performance, Optimized for Machine Tools

SVR/SVS

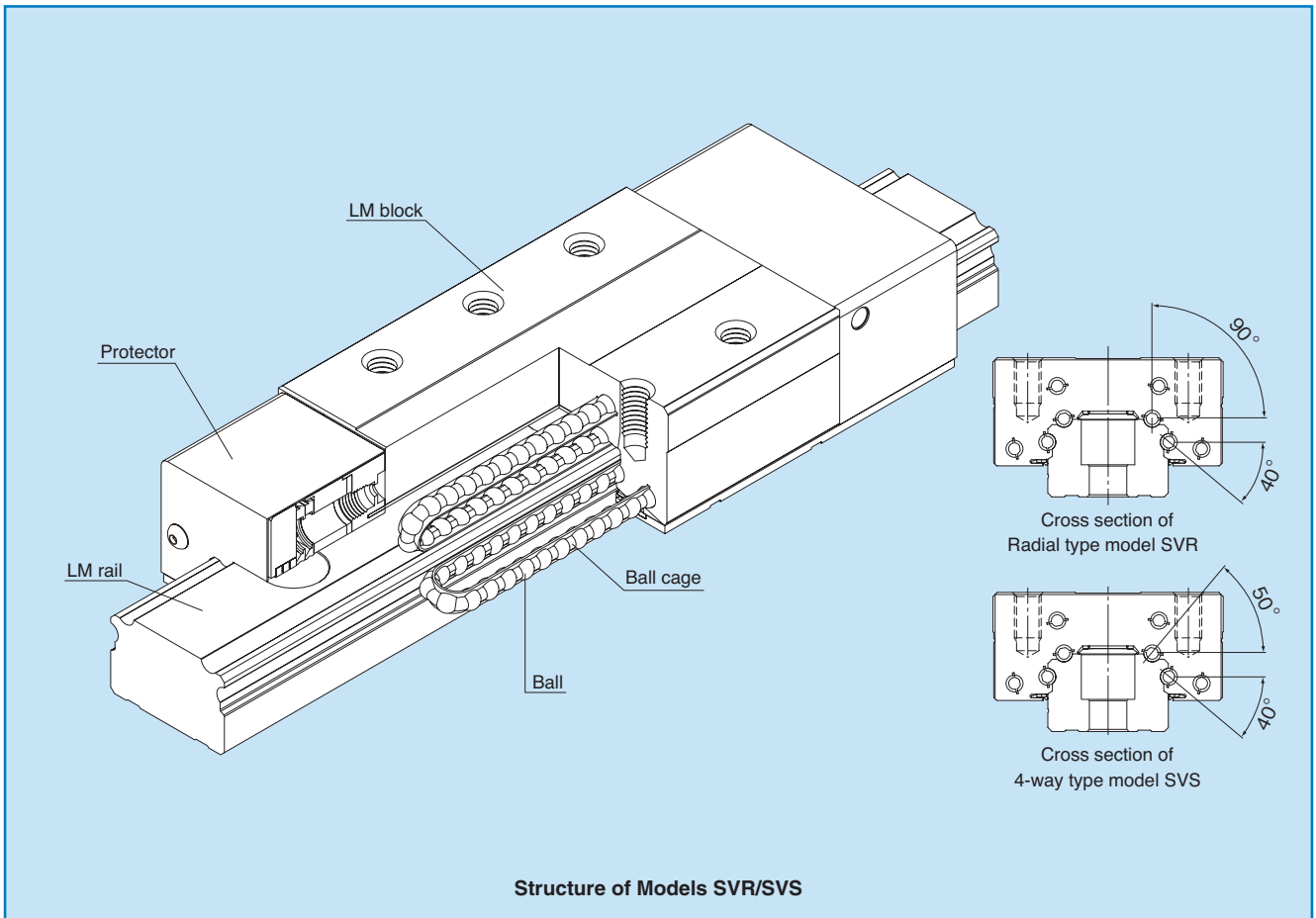

Structure of Models SVR/SVS

Models SVR/SVS have higher rigidity and load-bearing capacity than other models in the Caged-Ball LM Guide series. In addition, they maintain the performance of LM Guide and achieve high reliability by enhancing the dust-control performance with a wide range of options that take into account the service environments of machine tools and other machinery.

*1: They are interchangeable with models SNR/SNS in mounting dimensions.

*2: Since models SVR/SVS have very high rigidity, their structures are susceptible to a misalignment of the mounting surface and mounting error. The impact of such factors may shorten the service life or impair the movement. If you consider selecting these models, contact THK.

● Ultra-heavy load, increased damping effect

The raceway of models SVR/SVS adopts a circular-arc deep groove with a curvature approximate to the ball diameter. This enables the ball contact area to increase in response to the increase in the applied load, achieves a large load carrying capacity and increases the damping effect.

● High rigidity

Models SVR/SVS are the most rigid types among the Caged Ball LM Guide series.

Both the radial type SVR and the 4-way type SVS are available for each size variation. Depending on the intended use, you can select either type.

● Improved dust-control performance

The foreign material removal function has been enhanced to improve the dust-control performance through the introduction of a newly developed protector. In addition, these models adopt the side scraper to reduce entrance of foreign material into the LM block and maintain the LM Guide performance for a long period even in adverse environments.

● Wide array of options

Various options are available, including end seal, inner seal, side seal, Laminated Contact Scraper LaCS, protector, side scraper and GC-cap, to respond to diversified applications.

Models SVR/SVS Contamination Protection Performance Evaluation

Models SVR/SVS maintain their performance under severe condition with fine particle or liquid contamination.

Test conditions

Item	Description	
Tested model	SVS45LR1TTHHYC1+2880LP×2set	
Maximum speed	200m/min	
Stroke	2500mm	
Grease used	THK AFB-LF Grease	
Environmental conditions	Foreign material	Type: Metal powder Particle diameter: 125 μm or less (Atomized Powder) Amount: 0.4g/20min
	Coolant	Water-soluble Coolant Amount: 0.2cc/10s

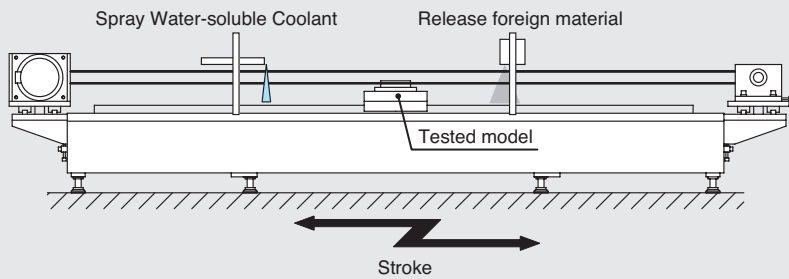
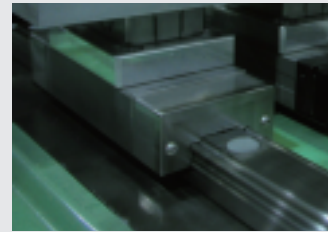
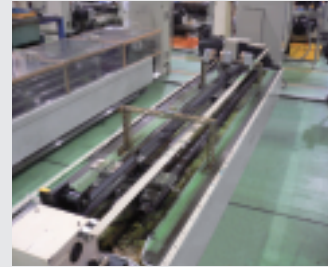

Models SVR/SVS with option (TTHYY option)

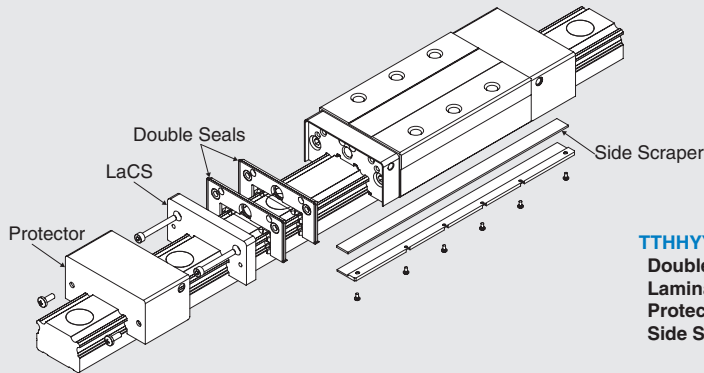

TTHYY Option

- Double Seal (→P.25~26)
- Laminated Contact Scraper LaCS (→P.25~26)
- Protector (→P.29)
- Side Scraper (→P.27)

Test Result



After traveling 3000 km

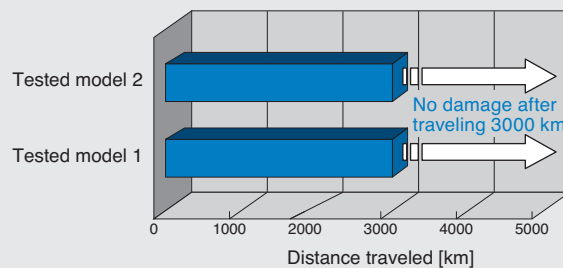

Models SVR/SVS maintain their performance even after traveling 3000 km under severe conditions with exposure to coolant and contamination.

● Models SVR/SVS Rigidity Evaluation Data

Rigidity of Models SVR/SVS is equal to or higher than conventional 4 Way Equal Load LM guide.

[Rigidity Data]

Rigidity in 4 directions (Radial, Reverse radial, Horizontal) is shown below.

■ Radial rigidity

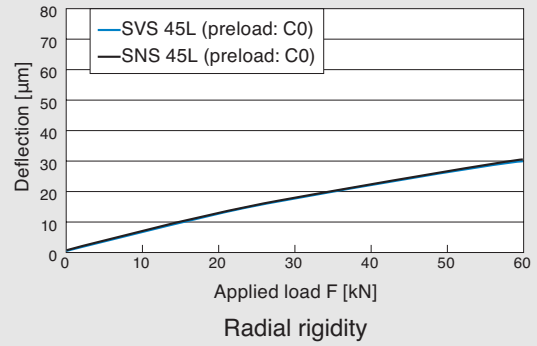
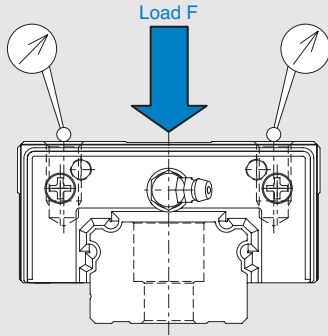

■ Reverse radial rigidity

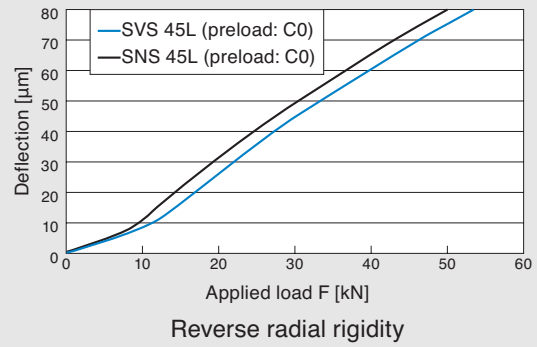
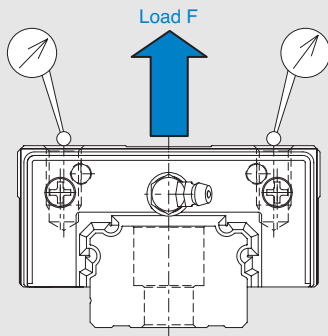

■ Horizontal rigidity

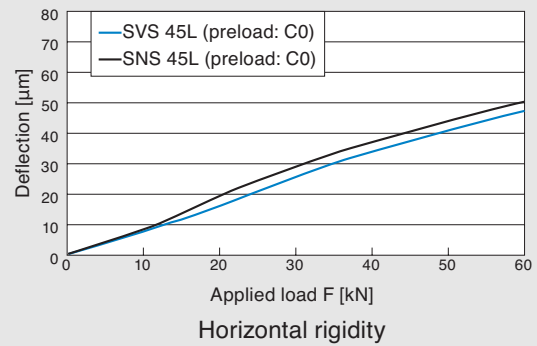
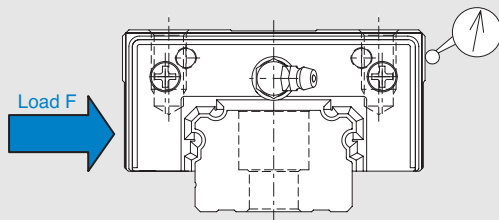

SVR/SVS Outline

Models SVR/SVS - Product Overview

Ultra-heavy load, high rigidity, and improved dust control performance

Radial type model SVR and 4-way type model SVS are available to select from.

Major applications Machining center / NC lathe / grinding machine / penta-plano milling machine

Models SVR-R/SVS-R

The LM block has a smaller width (W) and is equipped with tapped holes. It is suitable for places where space for the table width is limited.

- SVR/SVS 25R
- SVR/SVS 30R
- SVR/SVS 35R
- SVR/SVS 45R
- SVR/SVS 55R
- SVR/SVS 65R

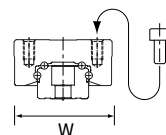
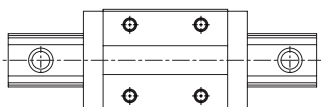

Models SVR-LR/SVS-LR

The LM block has the same sectional shape as models SVR-R/SVS-R, but has a longer overall LM block length (L) and a greater rated load.

- SVR/SVS 25LR
- SVR/SVS 30LR
- SVR/SVS 35LR
- SVR/SVS 45LR
- SVR/SVS 55LR
- SVR/SVS 65LR

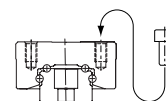
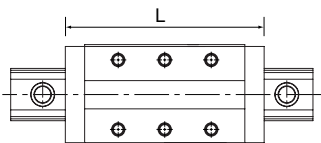

Models SVR-C/SVS-C

The flange of the LM block has tapped holes. It can be mounted from the top or the bottom. It can be used in places where the table cannot have through holes for mounting bolts.

- SVR/SVS 25C
- SVR/SVS 30C
- SVR/SVS 35C
- SVR/SVS 45C
- SVR/SVS 55C
- SVR/SVS 65C

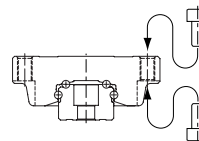
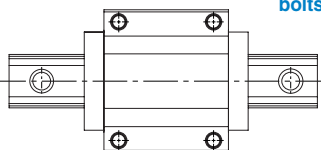

Models SVR-LC/SVS-LC

The LM block has the same sectional shape as models SVR-C/SVS-C, but has a longer overall LM block length (L) and a greater rated load.

- SVR/SVS 25LC
- SVR/SVS 30LC
- SVR/SVS 35LC
- SVR/SVS 45LC
- SVR/SVS 55LC
- SVR/SVS 65LC

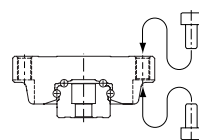
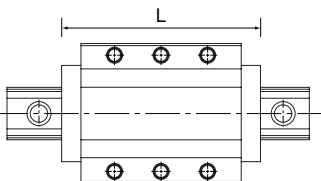

Build-to-order Models

Models SVR-RH/SVS-RH

The height (M) and width (W) dimensions are the same as that of LM Guide models SHS and HSR, and the LM block has tapped holes.

- SVR/SVS 35RH
- SVR/SVS 45RH
- SVR/SVS 55RH

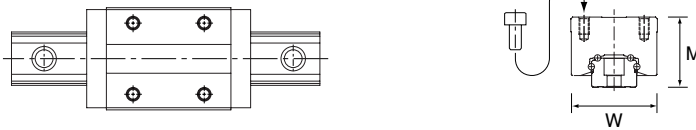

Models SVR-LRH/SVS-LRH

The LM block has the same sectional shape as models SVR-RH/SVS-RH, but has a longer overall LM block length (L) and a greater rated load.

- SVR/SVS 35LRH
- SVR/SVS 45LRH
- SVR/SVS 55LRH

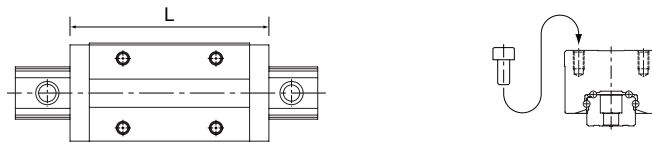

Models SVR-CH/SVS-CH

The height (M) and width (W) dimensions are the same as that of LM Guide models SHS and HSR, and the flange of the LM block has tapped holes.

- SVR/SVS 35CH
- SVR/SVS 45CH
- SVR/SVS 55CH

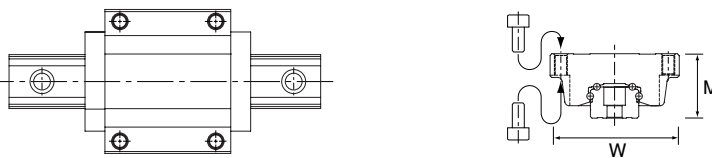

Models SVR-LCH/SVS-LCH

The LM block has the same sectional shape as models SVR-CH/SVS-CH, but has a longer overall LM block length (L) and a greater rated load.

- SVR/SVS 35LCH
- SVR/SVS 45LCH
- SVR/SVS 55LCH

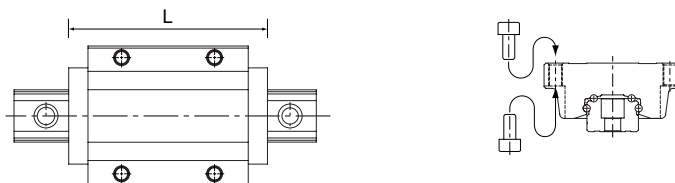

*1: Dimensional table for models SVR/SVS

Model SVR-R/LR
→ pages 13 to 14

Model SVS-R/LR
→ pages 15 to 16

Model SVR-C/LC
→ pages 17 to 18

Model SVS-C/LC
→ pages 19 to 20

Model SVR-RH/LRH
→ pages 21

Model SVS-RH/LRH
→ pages 21

Model SVR-CH/LCH
→ pages 22

Model SVS-CH/LCH
→ pages 22

Rated Loads in All Directions

Models SVR/SVS are capable of receiving loads in all four directions: radial, reverse-radial and lateral directions.

Their basic dynamic load ratings are represented by the symbols in the radial direction indicated in the figure on the right, and the actual values are provided in the dimensional tables*1 for SVR/SVS. The values in the reverse-radial and lateral directions are obtained from the table.

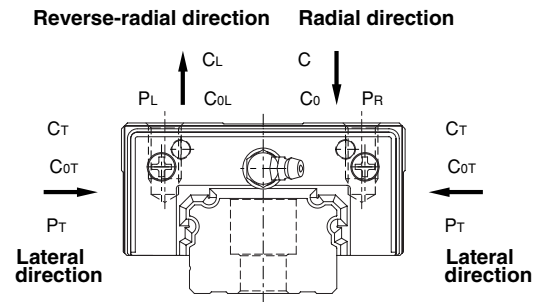

Rated Loads of Models SVR/SVS in All Directions

Direction	Model SVR	
	Basic dynamic load rating	Basic static load rating
Radial direction	C	C ₀
Reverse-radial direction	C _L =0.64C	C _{0L} =0.64C ₀
Lateral direction	C _T =0.47C	C _{0T} =0.38C ₀

Direction	Model SVS	
	Basic dynamic load rating	Basic static load rating
Radial direction	C	C ₀
Reverse-radial direction	C _L =0.84C	C _{0L} =0.84C ₀
Lateral direction	C _T =0.92C	C _{0T} =0.85C ₀

Equivalent Load

When the LM block of model SVR receives a reverse-radial load and a lateral load simultaneously, the equivalent load is obtained from the equation below.

$$P_E = X \cdot P_L + Y \cdot P_T$$

P_E : Equivalent load [N]
· Reverse-radial direction
P_L : Reverse-radial load [N]
P_T : Lateral load [N]
X, Y : Equivalent factor (see table 1)

Table 1 Equivalent Factor of Model SVR

P _E	X	Y
Equivalent load in reverse-radial direction	1	1.678

When the LM block of model SVS receives a radial load and a lateral load, or a reverse-radial load and a lateral load, simultaneously, the equivalent load is obtained from the equation below.

$$P_E = X \cdot P_R (P_L) + Y \cdot P_T$$

P_E : Equivalent load [N]
· Radial direction
· Reverse-radial direction
P_R : Radial load [N]
P_L : Reverse-radial load [N]
P_T : Lateral load [N]
X, Y : Equivalent factor (see tables 2 and 3)

Table 2 Equivalent Factor of Model SVS
(When radial load and lateral load are applied)

P _E	X	Y
Equivalent load in radial direction	1	0.935

Table 3 Equivalent Factor of Model SVS
(When reverse-radial load and lateral load are applied)

P _E	X	Y
Equivalent load in reverse-radial direction	1	1.02

Service life

The service life of an LM Guide is subject to variations even under the same operational conditions. Therefore, it is necessary to use the rated life defined below as a reference value for obtaining the service life of the LM Guide.

Rated life

The rated life means the total travel distance that 90% of a group of units of the same LM Guide model can achieve without flaking (scale-like exfoliation on the metal surface) after individually running under the same conditions.

Service life time

Once the rated life (L) has been obtained, the service life time can be obtained using the equation on the right if the stroke length and the number of reciprocations are constant.

*1: Basic dynamic load rating (C)

It refers to a load with a constant magnitude and direction under which the rated life (L) of a group of identical LM Guide units independently operating is 50 km.

$$L = \left(\frac{f_H \cdot f_T \cdot f_C}{f_W} \cdot \frac{C}{P_C} \right)^3 \times 50$$

L : Rated life [km]
C : Basic dynamic load rating*1 [N]
P_C : Calculated load [N]
f_H : Hardness factor (see Fig. 1)
f_T : Temperature factor
f_C : Contact factor (see Table 1)
f_W : Load factor (see Table 2)

$$L_h = \frac{L \times 10^6}{2 \times \ell_s \times n_1 \times 60}$$

L_h : Service life time [h]
ℓ_s : Stroke length [mm]
n₁ : No. of reciprocations per min [min⁻¹]

f_H : Hardness factor

To ensure the achievement of the optimum load capacity of the LM Guide, the raceway hardness must be between 58 and 64 HRC. At hardness below this range, the basic dynamic and static load ratings decrease. Therefore, the rating values must be multiplied by the respective hardness factors (f_H). Since the LM Guide has sufficient hardness, the f_H value for the LM Guide is normally 1.0 unless otherwise specified.

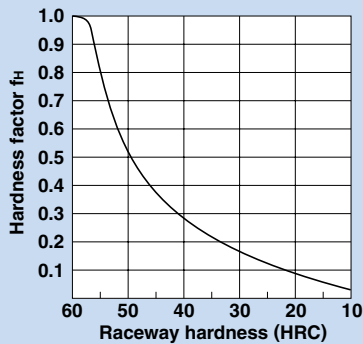

Fig. 1 Hardness factor (f_H)

f_C : Contact factor

When multiple LM blocks are used in close contact with each other, it is difficult to achieve uniform load distribution due to moment loads and mounting-surface accuracy. When using multiple blocks in close contact with each other, multiply the basic load rating (C or C₀) by the corresponding contact factor indicated in Table 1.

Note: When uneven load distribution is expected in a large machine, consider using a contact factor from Table 1.

Table 1 Contact Factor (f_C)

Number of blocks used in close contact	Contact factor f _C
2	0.81
3	0.72
4	0.66
5	0.61
6 or more	0.6
Normal use	1

f_T : Temperature factor

Since the service temperature of Caged Ball LM Guides is normally 80°C or below, the f_T value is 1.0.

f_W : Load factor

In general, reciprocating machines tend to produce vibrations or impact during operation. It is especially difficult to accurately determine all vibrations generated during high-speed operation and impacts produced each time the machine starts and stops. Therefore, where the effects of speed and vibration are estimated to be significant, divide the basic dynamic load rating (C) by a load factor selected from Table 2, which contains empirically obtained data.

Table 2 Load Factor (f_W)

Vibration/impact	Speed (V)	f _W
Faint	Very slow V ≤ 0.25m/s	1 to 1.2
Weak	Slow 0.25 < V ≤ 1m/s	1.2 to 1.5
Moderate	Medium 1 < V ≤ 2m/s	1.5 to 2
Strong	Fast V > 2m/s	2 to 3.5

***1: Preload**

Preload is an internal load applied to the rolling elements (balls, rollers, etc.) of an LM block in advance in order to increase its rigidity. The clearance of all model SVR/SVS units is adjusted to the designated value before being shipped. Therefore, it is unnecessary to adjust the preload.

Radial Clearance Standard

Since the radial clearance of an LM Guide greatly affects the running accuracy, load carrying capacity and rigidity of the LM Guide, it is important to select an appropriate clearance according to the application.

In general, selecting a negative clearance (i.e., a preload*1 is applied) while taking into account possible vibrations and impact generated from reciprocating motion favorably affects the service life and the accuracy.

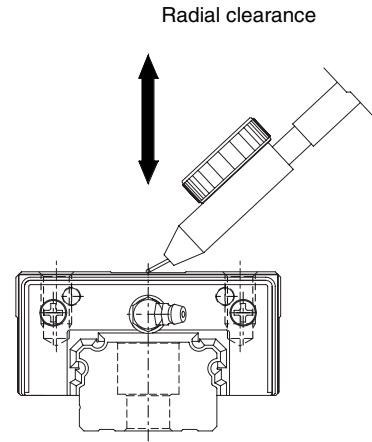

Unit: μm

Model No.	Indication symbol	Normal	Light preload	Moderate preload
	No symbol	C1	C0	
25	- 3 to +2	- 6 to - 3	- 9 to - 6	
30	- 4 to +2	- 8 to - 4	-12 to - 8	
35	- 4 to +2	- 8 to - 4	-12 to - 8	
45	- 5 to +3	-10 to - 5	-15 to -10	
55	- 6 to +3	-11 to - 6	-16 to -11	
65	- 8 to +3	-14 to - 8	-20 to -14	

Accuracy Standard

The accuracy of model SVR/SVS is specified in terms of running parallelism (*1), dimensional tolerance for height and width, and height and width difference between a pair (*2,*3) when two or more LM blocks are used on one rail or when two or more rails are mounted on the same plane.

The accuracy of model SVR/SVS is categorized into Normal grade (no symbol), High-accuracy grade (H), Precision grade (P), Super precision grade (SP) and Ultra precision grade (UP) by model numbers, as indicated in the table below.

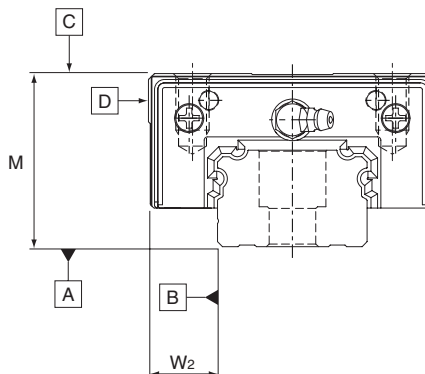

***1: Running parallelism**

It refers to the parallelism error between the LM block and the LM rail datum plane when the LM block travels the whole length of the LM rail with the LM rail secured on the reference datum plane using bolts.

***2: Difference in height M**

It indicates the difference between the minimum and maximum values of height (M) of each of the LM blocks used on the same plane in combination.

***3: Difference in width W₂**

It indicates the difference between the minimum and maximum values of the width (W₂) between each of the LM blocks, mounted on one LM rail in combination, and the LM rail.

Unit: mm

Model No.	Accuracy standard Item	Normal grade	High-accuracy grade	Precision grade	Super precision grade	Ultra precision grade	
		No Symbol	H	P	SP	UP	
25 30 35	Dimensional tolerance for height M	±0.08	±0.04	⁰ _{-0.04}	⁰ _{-0.02}	⁰ _{-0.01}	
	Difference in height M	0.02	0.015	0.007	0.005	0.003	
	Dimensional tolerance for width W ₂	±0.07	±0.03	⁰ _{-0.03}	⁰ _{-0.015}	⁰ _{-0.01}	
	Difference in width W ₂	0.025	0.015	0.007	0.005	0.003	
	Running parallelism of surface [C] against surface [A]	as shown in the table below					
	Running parallelism of surface [D] against surface [B]	as shown in the table below					
45 55	Dimensional tolerance for height M	±0.08	±0.04	⁰ _{-0.05}	⁰ _{-0.03}	⁰ _{-0.015}	
	Difference in height M	0.025	0.015	0.007	0.005	0.003	
	Dimensional tolerance for width W ₂	±0.07	±0.04	⁰ _{-0.04}	⁰ _{-0.025}	⁰ _{-0.015}	
	Difference in width W ₂	0.03	0.015	0.007	0.005	0.003	
	Running parallelism of surface [C] against surface [A]	as shown in the table below					
	Running parallelism of surface [D] against surface [B]	as shown in the table below					
65	Dimensional tolerance for height M	±0.08	±0.04	⁰ _{-0.05}	⁰ _{-0.04}	⁰ _{-0.03}	
	Difference in height M	0.03	0.02	0.01	0.007	0.005	
	Dimensional tolerance for width W ₂	±0.08	±0.04	⁰ _{-0.05}	⁰ _{-0.04}	⁰ _{-0.03}	
	Difference in width W ₂	0.03	0.02	0.01	0.007	0.005	
	Running parallelism of surface [C] against surface [A]	as shown in the table below					
	Running parallelism of surface [D] against surface [B]	as shown in the table below					

LM Rail Length and Running Parallelism for Models SVR/SVS

Unit: μm

LM rail length (mm)		Running Parallelism Values				
Above	Or less	Normal grade No Symbol	High-accuracy grade H	Precision grade P	Super precision grade SP	Ultra precision grade UP
—	50	5	3	2	1.5	1
50	80	5	3	2	1.5	1
80	125	5	3	2	1.5	1
125	200	5	3.5	2	1.5	1
200	250	6	4	2.5	1.5	1
250	315	7	4.5	3	1.5	1
315	400	8	5	3.5	2	1.5
400	500	9	6	4.5	2.5	1.5
500	630	11	7	5	3	2
630	800	12	8.5	6	3.5	2
800	1000	13	9	6.5	4	2.5
1000	1250	15	11	7.5	4.5	3
1250	1600	16	12	8	5	4
1600	2000	18	13	8.5	5.5	4.5
2000	2500	20	14	9.5	6	5
2500	3090	21	16	11	6.5	5.5

Shoulder Height of the Mounting Base and the Corner Radius

Normally, the mounting base for the LM rail and the LM block has a datum plane on the side face of the shoulder of the base in order to allow easy installation and highly accurate positioning.

The corner of the mounting shoulder must be machined to have a recess, or machined to be smaller than the corner radius "r," to prevent interference with the chamfer of the LM rail or the LM block.

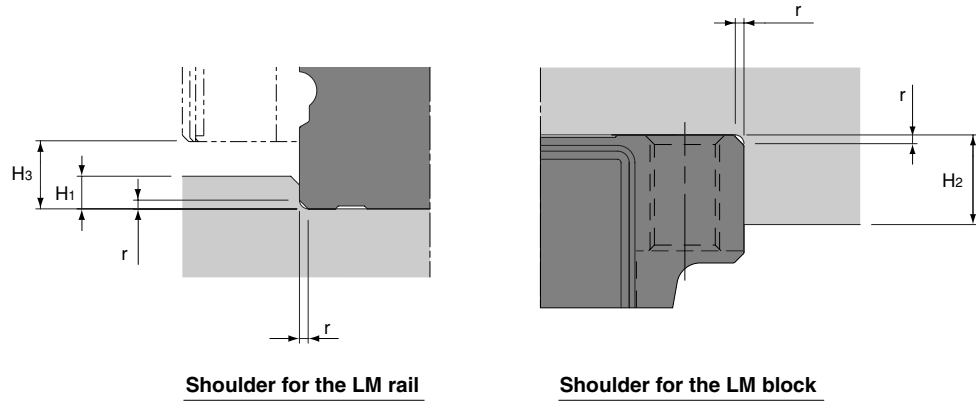

Unit: mm

Model No.	Corner radius r (max)	Shoulder height for the LM rail H ₁	Shoulder height for the LM block H ₂	H ₃
25	0.5	4	5	5.5
30	1	5	5	7
35	1	6	6	9
45	1	8	8	11.6
55	1.5	10	10	14
65	1.5	10	10	15

Error Allowance in the Parallelism Between Two Rails

The following table shows error allowances in parallelism (P) between two rails that will not affect the service life in normal operation.

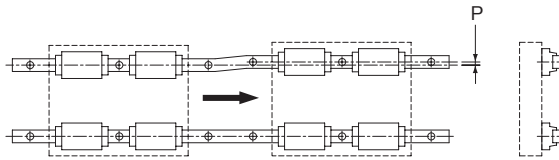

■ Model SVR

Unit: μm

Model No.	Clearance C0	Clearance C1	Normal clearance
25	14	15	21
30	19	21	28
35	21	25	35
45	25	28	42
55	32	35	49
65	39	42	56

■ Model SVS

Unit: μm

Model No.	Clearance C0	Clearance C1	Normal clearance
25	10	11	15
30	14	15	20
35	15	18	25
45	18	20	30
55	23	25	35
65	28	30	40

Error Allowance in Vertical Level Between Two Rails

The values in the tables indicate the error allowances in vertical level (S) between two rails per 500 mm of the axis-to-axis distance, and are proportional to the axis-to-axis distances.

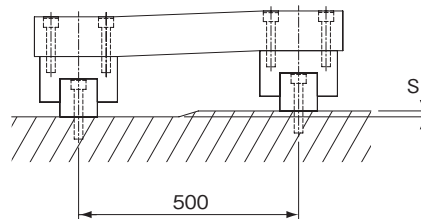

■ Model SVR

Unit: μm

Model No.	Clearance C0	Clearance C1	Normal clearance
25	35	43	65
30	45	55	85
35	60	75	105
45	70	85	125
55	85	105	150
65	100	125	175

■ Model SVS

Unit: μm

Model No.	Clearance C0	Clearance C1	Normal clearance
25	49	60	91
30	63	77	119
35	84	105	147
45	98	119	175
55	119	147	210
65	140	175	245

Models SVR-R/SVR-LR

Dimensional Table for Models SVR-R/SVR-LR

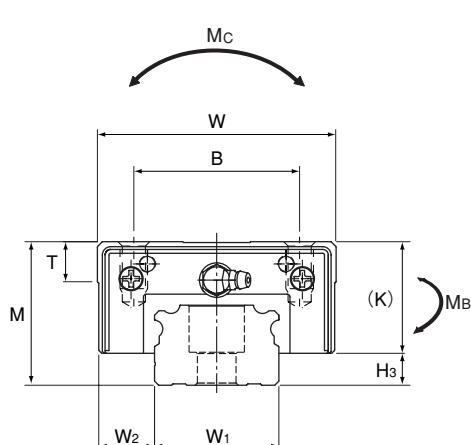

Model SVR-R/LR

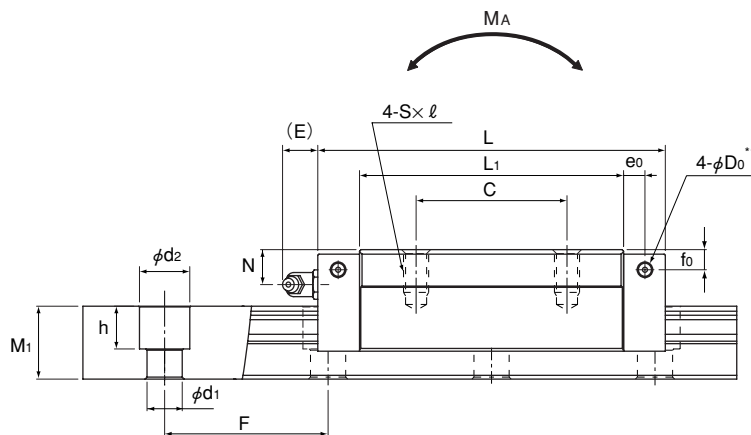

Model SVR-R

Model No.	Outer dimensions			LM block dimensions													H ₃
	Height M	Width W	Length L	B	C	S × l	L ₁	T	K	N	f ₀	E	e ₀	D ₀	Grease nipple		
SVR 25R SVR 25LR	31	50	82.8 102	32	35 50	M6×8	61.4 80.6	9.7	25.5	7.8	5.1	12	4.5	3.9	B-M6F	5.5	
SVR 30R SVR 30LR	38	60	98 120.5	40	40 60	M8×10	72.1 94.6	9.7	31	10.3	7	12	6.5	3.9	B-M6F	7	
SVR 35R SVR 35LR	44	70	109.5 135	50	50 72	M8×12	79 104.5	11.7	35	12.1	8	12	6	5.2	B-M6F	9	
SVR 45R SVR 45LR	52	86	138.2 171	60	60 80	M10×17	105 137.8	14.7	40.4	13.9	8	16	8.5	5.2	B-PT1/8	11.6	
SVR 55R SVR 55LR	63	100	163.3 200.5	65	75 95	M12×18	123.6 160.8	17.7	49	16.6	10	16	10	5.2	B-PT1/8	14	
SVR 65R SVR 65LR	75	126	186 246	76	70 110	M16×20	143.6 203.6	21.6	60	19	15	16	8.7	8.2	B-PT1/8	15	

Example of model number coding

SVR45 LR 2 QZ TTHH C0 +1200L P T - II

1 2 3 4 5 6 7 8 9 10

1 Model number 2 Type of LM block 3 No. of LM blocks used on the same rail 4 With QZ Lubricator

5 Dust prevention accessory symbol (see page 25) 6 Radial clearance symbol (see page 7)

7 LM rail length (in mm) 8 Accuracy symbol (see page 8) 9 Symbol for LM rail jointed use 10 No. of rails used on the same plane

Note This model number indicates that an LM block and an LM rail constitute one set (i.e., the required number of sets when 2 rails are used in parallel is 2). Those models equipped with QZ Lubricator cannot have a grease nipple.

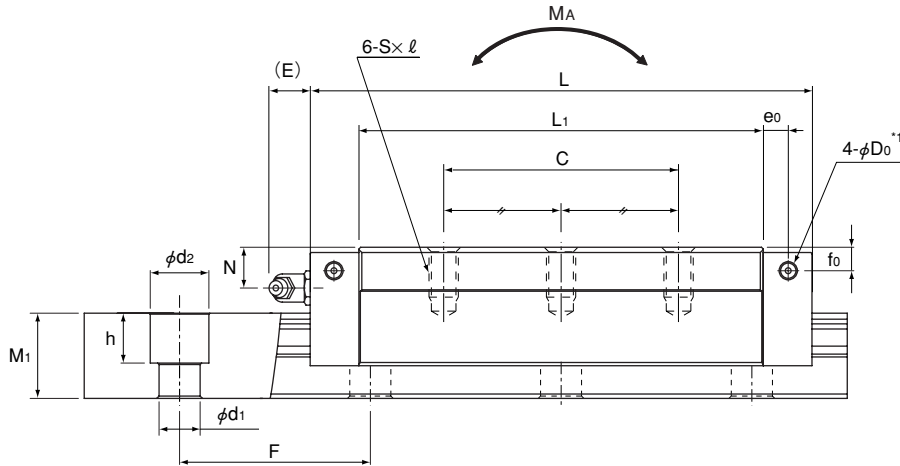

Model SVR-LR

Unit: mm

	LM rail dimensions						Basic load rating		Static permissible moment kN-m ^{*3}					Mass	
	Width W ₁ 0 -0.05	W ₂	Height M ₁	Pitch F	d ₁ ×d ₂ ×h	Length Max ^{*2}	C [kN]	C ₀ [kN]	M _A		M _B		M _C	LM block [kg]	LM rail [kg/m]
									1 block	Double blocks	1 block	Double blocks			
	25	12.5	17	40	6×9.5×8.5	2500	48	68	0.569	2.95	0.391	2.61	0.720	0.4	2.9
57							86	0.890	4.74	0.612	4.21	0.912			
	28	16	21	80	7×11×9	3000	68	99	0.859	5.07	0.588	4.29	1.09	0.7	4.2
81							126	1.52	7.78	1.04	6.61	1.48			
	34	18	24.5	80	9×14×12	3000	90	115	1.19	7.19	0.812	6.17	1.65	1	6.0
108							159	2.21	11.1	1.50	9.63	2.28			
	45	20.5	29	105	14×20×17	3090	132	173	2.61	13.0	1.80	11.8	3.51	1.8	9.5
161							231	3.98	20.8	2.75	18.8	4.39			
	53	23.5	36.5	120	16×23×20	3060	177	238	3.78	20.5	2.59	18.6	5.13	3.3	14
214							312	6.35	30.8	4.35	28.0	6.73			
	63	31.5	43	150	18×26×22	3000	260	328	6.18	33.7	4.11	28.3	8.47	6.0	19.6
340							481	12.8	60.2	8.52	50.7	12.4			

Note

*1 Pilot holes for side nipples are not drilled through in order to prevent foreign material from entering the product. THK will mount grease nipples per your request. Therefore, do not use the side nipple pilot holes for purposes other than mounting a grease nipple.

*2 The maximum length under "Length" indicates the standard maximum length of an LM rail.

*3 Static permissible moment: 1 block: Static permissible moment value with 1 LM block

Double blocks: Static permissible moment value with 2 blocks closely contacting with each other

Models SVS-R/SVS-LR

Dimensional Table for Models SVS-R/SVS-LR

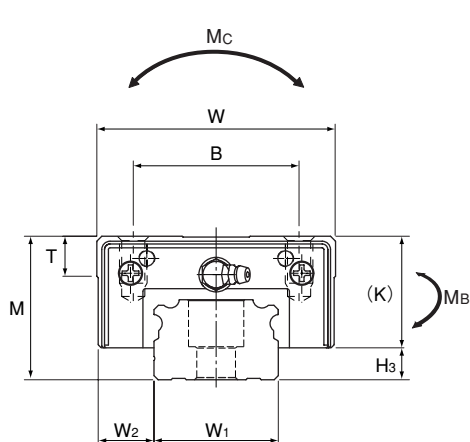

Model SVS-R/LR

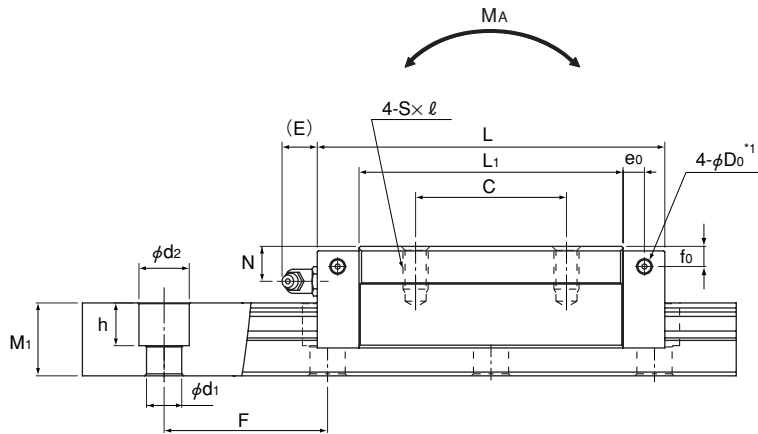

Model SVS-R

Model No.	Outer dimensions			LM block dimensions													H ₃
	Height M	Width W	Length L	B	C	S × l	L ₁	T	K	N	f ₀	E	e ₀	D ₀	Grease nipple		
SVS 25R SVS 25LR	31	50	82.8 102	32	35 50	M6×8	61.4 80.6	9.7	25.5	7.8	5.1	12	4.5	3.9	B-M6F	5.5	
SVS 30R SVS 30LR	38	60	98 120.5	40	40 60	M8×10	72.1 94.6	9.7	31	10.3	7	12	6.5	3.9	B-M6F	7	
SVS 35R SVS 35LR	44	70	109.5 135	50	50 72	M8×12	79 104.5	11.7	35	12.1	8	12	6	5.2	B-M6F	9	
SVS 45R SVS 45LR	52	86	138.2 171	60	60 80	M10×17	105 137.8	14.7	40.4	13.9	8	16	8.5	5.2	B-PT1/8	11.6	
SVS 55R SVS 55LR	63	100	163.3 200.5	65	75 95	M12×18	123.6 160.8	17.7	49	16.6	10	16	10	5.2	B-PT1/8	14	
SVS 65R SVS 65LR	75	126	186 246	76	70 110	M16×20	143.6 203.6	21.6	60	19	15	16	8.7	8.2	B-PT1/8	15	

Example of model number coding

SVS45 LR 2 QZ TTHH C0 +1200L P T - II

1 2 3 4 5 6 7 8 9 10

1 Model number 2 Type of LM block 3 No. of LM blocks used on the same rail 4 With QZ Lubricator

5 Dust prevention accessory symbol (see page 25) 6 Radial clearance symbol (see page 7)

7 LM rail length (in mm) 8 Accuracy symbol (see page 8) 9 Symbol for LM rail jointed use 10 No. of rails used on the same plane

Note This model number indicates that an LM block and an LM rail constitute one set (i.e., the required number of sets when 2 rails are used in parallel is 2). Those models equipped with QZ Lubricator cannot have a grease nipple.

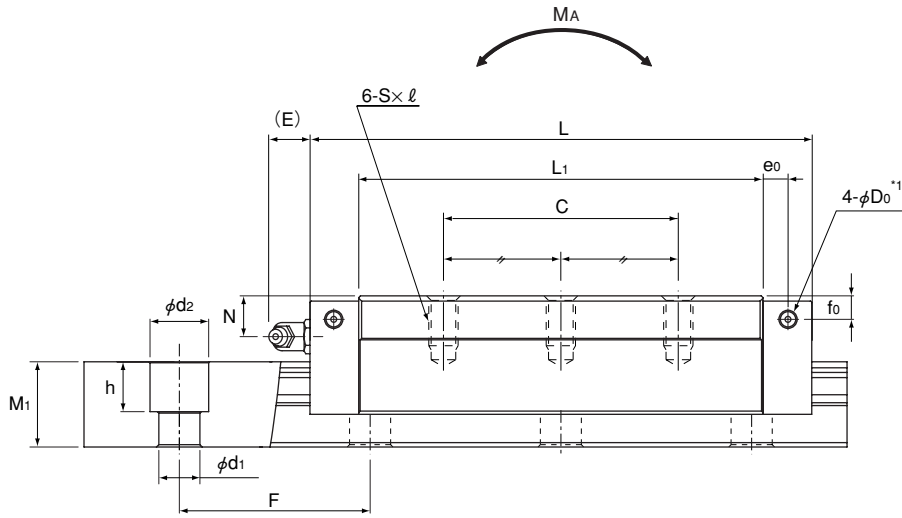

Model SVS-LR

Unit: mm

	LM rail dimensions						Basic load rating		Static permissible moment [kN-m] ^{*3}					Mass	
	Width W ₁ 0 -0.05	W ₂	Height M ₁	Pitch F	d ₁ ×d ₂ ×h	Length Max ^{*2}	C [kN]	C ₀ [kN]	M _A		M _B		M _C	LM block [kg]	LM rail [kg/m]
									1 block	Double blocks	1 block	Double blocks			
	25	12.5	17	40	6×9.5×8.5	2500	37 44	52 66	0.534 0.837	2.77 4.44	0.578 0.908	2.33 3.75	0.639 0.810	0.4 0.5	2.9
	28	16	21	80	7×11×9	3000	52 62	76 96	0.807 1.43	4.74 7.28	0.868 1.55	4.01 6.17	0.969 1.31	0.7 0.9	4.2
	34	18	24.5	80	9×14×12	3000	69 83	88 122	1.11 2.05	6.78 10.5	1.20 2.22	5.64 8.79	1.47 2.03	1 1.3	6.0
	45	20.5	29	105	14×20×17	3090	101 123	133 177	2.45 3.74	12.3 19.6	2.67 4.08	10.3 16.5	3.15 3.94	1.8 2.3	9.5
	53	23.5	36.5	120	16×23×20	3060	136 164	182 239	3.55 5.95	19.2 28.8	3.85 6.49	16.3 24.5	4.56 5.99	3.3 4.3	14
	63	31.5	43	150	18×26×22	3000	199 261	251 368	5.79 12.0	31.6 56.4	6.05 12.5	27.2 48.8	7.52 11.0	6.0 8.5	19.6

Note

*1 Pilot holes for side nipples are not drilled through in order to prevent foreign material from entering the product. THK will mount grease nipples per your request. Therefore, do not use the side nipple pilot holes for purposes other than mounting a grease nipple.

*2 The maximum length under "Length" indicates the standard maximum length of an LM rail.

*3 Static permissible moment: 1 block: Static permissible moment value with 1 LM block
Double blocks: Static permissible moment value with 2 blocks closely contacting with each other

Models SVR-C/SVR-LC

Dimensional Table for Models SVR-C/SVR-LC

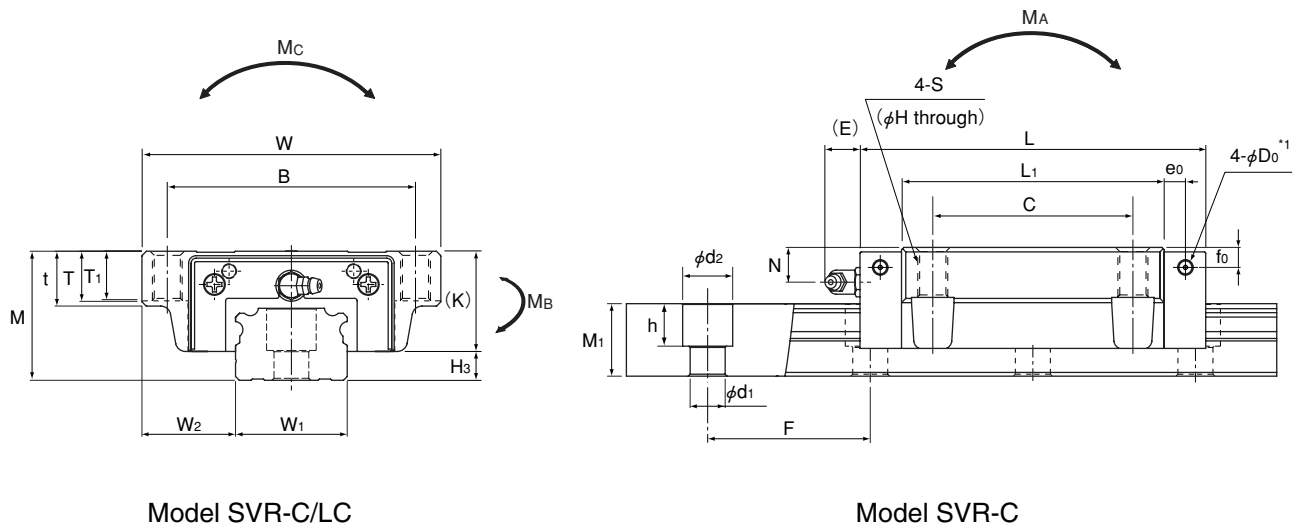

Model SVR-C/LC

Model SVR-C

Model No.	Outer dimensions			LM block dimensions																H ₃
	Height	Width	Length	B	C	S	H	L ₁	t	T	T ₁	K	N	f ₀	E	e ₀	D ₀	Grease nipple		
	M	W	L	B	C	S	H	L ₁	t	T	T ₁	K	N	f ₀	E	e ₀	D ₀	Grease nipple		
SVR 25C SVR 25LC	31	72	82.8 102	59	45	M8	6.8	61.4 80.6	16	14.8	12	25.5	7.8	5.1	12	4.5	3.9	B-M6F	5.5	
SVR 30C SVR 30LC	38	90	98 120.5	72	52	M10	8.5	72.1 94.6	18.1	16.9	14	31	10.3	7	12	6.5	3.9	B-M6F	7	
SVR 35C SVR 35LC	44	100	109.5 135	82	62	M10	8.5	79 104.5	20.1	18.9	16	35	12.1	8	12	6	5.2	B-M6F	9	
SVR 45C SVR 45LC	52	120	138.2 171	100	80	M12	10.5	105 137.8	22.1	20.6	20	40.4	13.9	8	16	8.5	5.2	B-PT1/8	11.6	
SVR 55C SVR 55LC	63	140	163.3 200.5	116	95	M14	12.5	123.6 160.8	24	22.5	22	49	16.6	10	16	10	5.2	B-PT1/8	14	
SVR 65C SVR 65LC	75	170	186 246	142	110	M16	14.5	143.6 203.6	28	26	25	60	19	15	16	8.7	8.2	B-PT1/8	15	

Example of model number coding

SVR45 LC 2 QZ TTHH C0 +1200L P T - II

1 2 3 4 5 6 7 8 9 10

1 Model number 2 Type of LM block 3 No. of LM blocks used on the same rail 4 With QZ Lubricator

5 Dust prevention accessory symbol (see page 25) 6 Radial clearance symbol (see page 7)

7 LM rail length (in mm) 8 Accuracy symbol (see page 8) 9 Symbol for LM rail jointed use 10 No. of rails used on the same plane

Note This model number indicates that an LM block and an LM rail constitute one set (i.e., the required number of sets when 2 rails are used in parallel is 2). Those models equipped with QZ Lubricator cannot have a grease nipple.

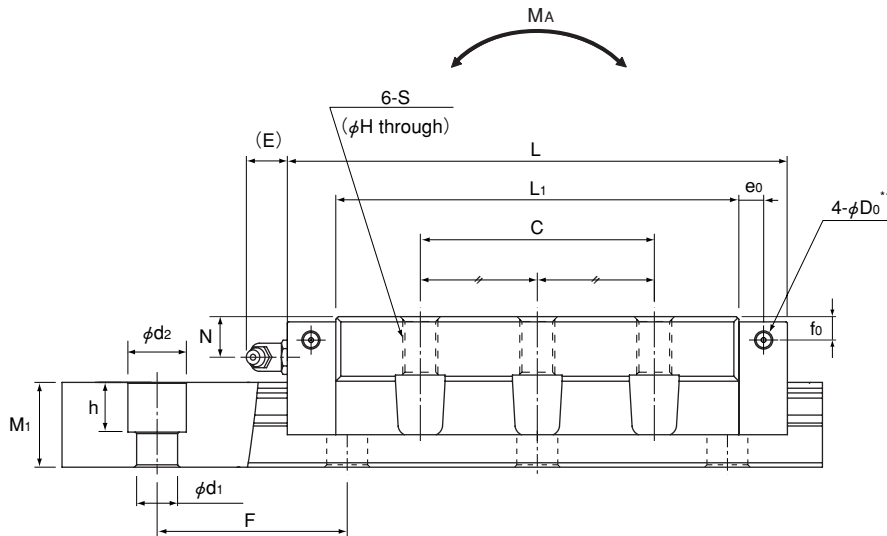

Model SVR-LC

Unit: mm

	LM rail dimensions						Basic load rating		Static permissible moment [kN-m] ^{*3}					Mass	
	Width W ₁ 0 -0.05	W ₂	Height M ₁	Pitch F	d ₁ ×d ₂ ×h	Length Max ^{*2}	C [kN]	C ₀ [kN]	M _A		M _B		M _C	LM block [kg]	LM rail [kg/m]
									1 block	Double blocks	1 block	Double blocks			
	25	23.5	17	40	6×9.5×8.5	2500	48 57	68 86	0.569 0.890	2.95 4.74	0.391 0.612	2.61 4.21	0.720 0.912	0.6 0.8	2.9
	28	31	21	80	7×11×9	3000	68 81	99 126	0.859 1.52	5.07 7.78	0.588 1.04	4.29 6.61	1.09 1.48	1.1 1.5	4.2
	34	33	24.5	80	9×14×12	3000	90 108	115 159	1.19 2.21	7.19 11.1	0.812 1.50	6.17 9.63	1.65 2.28	1.6 2	6.0
	45	37.5	29	105	14×20×17	3090	132 161	173 231	2.61 3.98	13.0 20.8	1.80 2.75	11.8 18.8	3.51 4.39	2.7 3.6	9.5
	53	43.5	36.5	120	16×23×20	3060	177 214	238 312	3.78 6.35	20.5 30.8	2.59 4.35	18.6 28.0	5.13 6.73	4.5 5.9	14
	63	53.5	43	150	18×26×22	3000	260 340	328 481	6.18 12.8	33.7 60.2	4.11 8.52	28.3 50.7	8.47 12.4	7.8 11.0	19.6

Note *1 Pilot holes for side nipples are not drilled through in order to prevent foreign material from entering the product. THK will mount grease nipples per your request. Therefore, do not use the side nipple pilot holes for purposes other than mounting a grease nipple.

*2 The maximum length under "Length" indicates the standard maximum length of an LM rail.

*3 Static permissible moment: 1 block: Static permissible moment value with 1 LM block
Double blocks: Static permissible moment value with 2 blocks closely contacting with each other

Models SVS-C/SVS-LC

Dimensional Table for Models SVS-C/SVS-LC

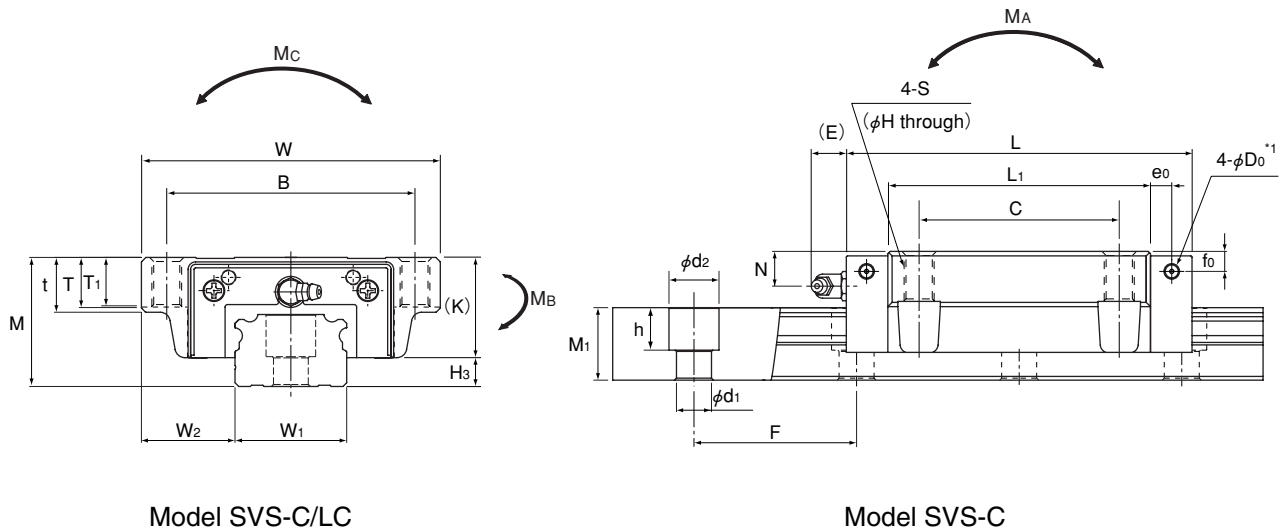

Model No.	Outer dimensions			LM block dimensions																H ₃
	Height	Width	Length	B	C	S	H	L ₁	t	T	T ₁	K	N	f ₀	E	e ₀	D ₀	Grease nipple		
	M	W	L	B	C	S	H	L ₁	t	T	T ₁	K	N	f ₀	E	e ₀	D ₀			
SVS 25C SVS 25LC	31	72	82.8 102	59	45	M8	6.8	61.4 80.6	16	14.8	12	25.5	7.8	5.1	12	4.5	3.9	B-M6F	5.5	
SVS 30C SVS 30LC	38	90	98 120.5	72	52	M10	8.5	72.1 94.6	18.1	16.9	14	31	10.3	7	12	6.5	3.9	B-M6F	7	
SVS 35C SVS 35LC	44	100	109.5 135	82	62	M10	8.5	79 104.5	20.1	18.9	16	35	12.1	8	12	6	5.2	B-M6F	9	
SVS 45C SVS 45LC	52	120	138.2 171	100	80	M12	10.5	105 137.8	22.1	20.6	20	40.4	13.9	8	16	8.5	5.2	B-PT1/8	11.6	
SVS 55C SVS 55LC	63	140	163.3 200.5	116	95	M14	12.5	123.6 160.8	24	22.5	22	49	16.6	10	16	10	5.2	B-PT1/8	14	
SVS 65C SVS 65LC	75	170	186 246	142	110	M16	14.5	143.6 203.6	28	26	25	60	19	15	16	8.7	8.2	B-PT1/8	15	

Example of model number coding

SVS45 LC 2 QZ TTHH C0 +1200L P T - II

1
2
3
4
5
6
7
8
9
10

1 Model number **2** Type of LM block **3** No. of LM blocks used on the same rail **4** With QZ Lubricator

5 Dust prevention accessory symbol (see page 25) **6** Radial clearance symbol (see page 7)

7 LM rail length (in mm) **8** Accuracy symbol (see page 8) **9** Symbol for LM rail jointed use **10** No. of rails used on the same plane

Note This model number indicates that an LM block and an LM rail constitute one set (i.e., the required number of sets when 2 rails are used in parallel is 2). Those models equipped with QZ Lubricator cannot have a grease nipple.

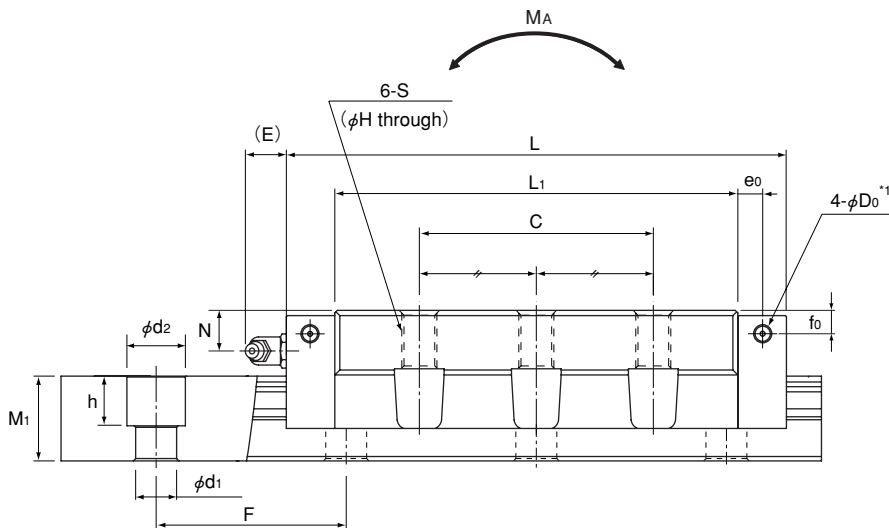

Model SVS-LC

Unit: mm

	LM rail dimensions						Basic load rating		Static permissible moment [kN-m] ^{*3}					Mass	
	Width W ₁ 0 -0.05	W ₂	Height M ₁	Pitch F	d ₁ ×d ₂ ×h	Length Max ^{*2}	C [kN]	C ₀ [kN]	M _A		M _B		M _C	LM block [kg]	LM rail [kg/m]
									1 block	Double blocks	1 block	Double blocks			
	25	23.5	17	40	6×9.5×8.5	2500	37 44	52 66	0.534 0.837	2.77 4.44	0.578 0.908	2.33 3.75	0.639 0.810	0.6 0.8	2.9
	28	31	21	80	7×11×9	3000	52 62	76 96	0.807 1.43	4.74 7.28	0.868 1.55	4.01 6.17	0.969 1.31	1.1 1.5	4.2
	34	33	24.5	80	9×14×12	3000	69 83	88 122	1.11 2.05	6.78 10.5	1.20 2.22	5.64 8.79	1.47 2.03	1.5 2	6.0
	45	37.5	29	105	14×20×17	3090	101 123	133 177	2.45 3.74	12.3 19.6	2.67 4.08	10.3 16.5	3.15 3.94	2.7 3.6	9.5
	53	43.5	36.5	120	16×23×20	3060	136 164	182 239	3.55 5.95	19.2 28.8	3.85 6.49	16.3 24.5	4.56 5.99	4.5 5.9	14
	63	53.5	43	150	18×26×22	3000	199 261	251 368	5.79 12.0	31.6 56.4	6.05 12.5	27.2 48.8	7.52 11.0	7.8 11.0	19.6

Note *1 Pilot holes for side nipples are not drilled through in order to prevent foreign material from entering the product. THK will mount grease nipples per your request. Therefore, do not use the side nipple pilot holes for purposes other than mounting a grease nipple.

*2 The maximum length under "Length" indicates the standard maximum length of an LM rail.

*3 Static permissible moment: 1 block: Static permissible moment value with 1 LM block
Double blocks: Static permissible moment value with 2 blocks closely contacting with each other

Models SVR-RH/SVR-LRH SVS-RH/SVS-LRH

Dimensional Table for Models SVR-RH/SVR-LRH SVS-RH/SVS-LRH Build-to-order Models

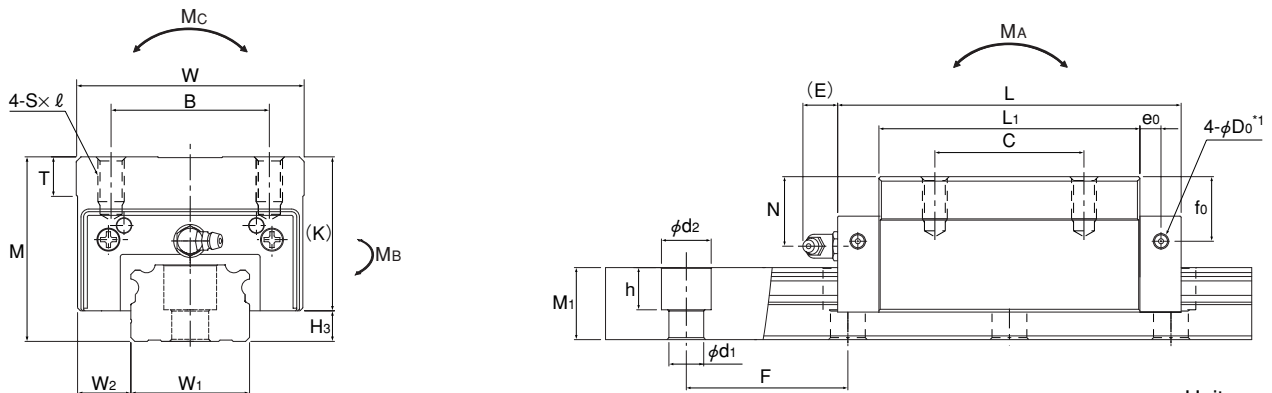

Unit: mm

Model No.	Outer dimensions			LM block dimensions											Grease nipple	H ₃
	Height M	Width W	Length L	B	C	S×ℓ	L ₁	T	K	N	f ₀	E	e ₀	D ₀		
SVR 35RH SVS 35RH	55	70	109.5	50	50	M8×12	79	11.7	46	23.1	19	12	6	5.2	B-M6F	9
SVR 35LRH SVS 35LRH	55	70	135	50	72	M8×12	104.5	11.7	46	23.1	19	12	6	5.2	B-M6F	9
SVR 45RH SVS 45RH	70	86	138.2	60	60	M10×17	105	14.7	58.4	31.9	26	16	8.5	5.2	B-PT1/8	11.6
SVR 45LRH SVS 45LRH	70	86	171	60	80	M10×17	137.8	14.7	58.4	31.9	26	16	8.5	5.2	B-PT1/8	11.6
SVR 55RH SVS 55RH	80	100	163.3	75	75	M12×18	123.6	17.7	66	33.6	27	16	10	5.2	B-PT1/8	14
SVR 55LRH SVS 55LRH	80	100	200.5	75	95	M12×18	160.8	17.7	66	33.6	27	16	10	5.2	B-PT1/8	14

Model No.	LM rail dimensions						Basic load rating		Static permissible moment [kN-m]*3					Mass	
	Width W ₀ -0.05	W ₂	Height M ₁	Pitch F	d ₁ ×d ₂ ×h	Length Max*2	C [kN]	C ₀ [kN]	M _A		M _B		M _C	LM block [kg]	LM rail [kg/m]
									1 block	Double blocks	1 block	Double blocks	1 block		
SVR 35RH SVS 35RH	34	18	24.5	80	9×14×12	3000	90	115	1.19	7.19	0.812	6.17	1.65	1.5	6.0
SVR 35LRH SVS 35LRH	34	18	24.5	80	9×14×12	3000	108	159	2.21	11.1	1.50	9.63	2.28	2	6.0
SVR 45RH SVS 45RH	45	20.5	29	105	14×20×17	3090	132	173	2.61	13.0	1.80	11.8	3.51	3.2	9.5
SVR 45LRH SVS 45LRH	45	20.5	29	105	14×20×17	3090	161	231	3.98	20.8	2.75	18.8	4.39	4.1	9.5
SVR 55RH SVS 55RH	53	23.5	36.5	120	16×23×20	3060	177	238	3.78	20.5	2.59	18.6	5.13	4.7	14
SVR 55LRH SVS 55LRH	53	23.5	36.5	120	16×23×20	3060	214	312	6.35	30.8	4.35	28.0	6.73	6.2	14

Note *1 Pilot holes for side nipples are not drilled through in order to prevent foreign material from entering the product. THK will mount grease nipples per your request. Therefore, do not use the side nipple pilot holes for purposes other than mounting a grease nipple.

*2 The maximum length under "Length" indicates the standard maximum length of an LM rail.

*3 Static Permissible moment: 1 block: Static permissible moment value with 1 LM block
Double blocks: Static permissible moment value with 2 blocks closely contacting with each other

■ Example of model number coding

SVR35 RH 2 QZ TTHH C0 +920L H T - II

1 2 3 4 5 6 7 8 9 10

1 Model number 2 Type of LM block 3 No. of LM blocks used on the same rail 4 With QZ Lubricator

5 Dust prevention accessory symbol (see page 25) 6 Radial clearance symbol (see page 7)

7 LM rail length (in mm) 8 Accuracy symbol (see page 8) 9 Symbol for LM rail jointed use 10 No. of rails used on the same plane

Note This model number indicates that an LM block and an LM rail constitute one set (i.e., the required number of sets when 2 rails are used in parallel is 2). Those models equipped with QZ Lubricator cannot have a grease nipple.

Models SVR-CH/SVR-LCH SVS-CH/SVS-LCH

Dimensional Table for Models SVR-CH/SVR-LCH SVS-CH/SVS-LCH Build-to-order Models

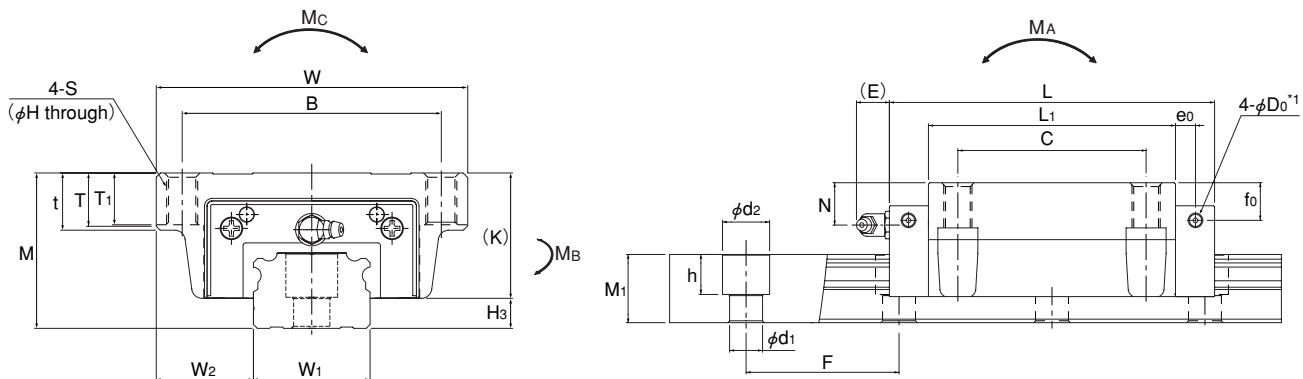

Unit: mm

Model No.	Outer dimensions			LM block dimensions															Grease nipple	H _s
	Height M	Width W	Length L	B	C	S	H	L ₁	t	T	T ₁	K	N	f _o	E	e _o	D _o			
SVR 35CH SVS 35CH	48	100	109.5	82	62	M10	8.5	79	20	19	16	39	16.1	12	12	6	5.2	B-M6F	9	
SVR 35LCH SVS 35LCH	48	100	135	82	62	M10	8.5	104.5	20	19	16	39	16.1	12	12	6	5.2	B-M6F	9	
SVR 45CH SVS 45CH	60	120	138.2	100	80	M12	10.5	105	22	20.5	20	48.4	21.9	16	16	8.5	5.2	B-PT1/8	11.6	
SVR 45LCH SVS 45LCH	60	120	171	100	80	M12	10.5	137.8	22	20.5	20	48.4	21.9	16	16	8.5	5.2	B-PT1/8	11.6	
SVR 55CH SVS 55CH	70	140	163.3	116	95	M14	12.5	123.6	24	22.5	22	56	23.6	17	16	10	5.2	B-PT1/8	14	
SVR 55LCH	70	140	200.5	116	95	M14	12.5	160.8	24	22.5	22	56	23.6	17	16	10	5.2	B-PT1/8	14	

Model No.	LM rail dimensions					Basic load rating		Static permissible moment [kN-m] ^{*3}				Mass			
	Width W ₁ -0.05	W ₂	Height M ₁	Pitch F	d ₁ ×d ₂ ×h	Length Max ^{*2}	C [kN]	C ₀ [kN]	M _A		M _B		M _C	LM block [kg]	LM rail [kg/m]
SVR 35CH SVS 35CH	34	33	24.5	80	9×14×12	3000	90 69	115 88	1.19 1.11	7.19 6.78	0.812 1.20	6.17 5.64	1.65 1.47	1.7	6.0
SVR 35LCH SVS 35LCH	34	33	24.5	80	9×14×12	3000	108 83	159 122	2.21 2.05	11.1 10.5	1.50 2.22	9.63 8.79	2.28 2.03	2.2	6.0
SVR 45CH SVS 45CH	45	37.5	29	105	14×20×17	3090	132 101	173 133	2.61 2.45	13.0 12.3	1.80 2.67	11.8 10.3	3.51 3.15	3	9.5
SVR 45LCH SVS 45LCH	45	37.5	29	105	14×20×17	3090	161 123	231 177	3.98 3.74	20.8 19.6	2.75 4.08	18.8 16.5	4.39 3.94	4.2	9.5
SVR 55CH SVS 55CH	53	43.5	36.5	120	16×23×20	3060	177 136	238 182	3.78 3.55	20.5 19.2	2.59 3.85	18.6 16.3	5.13 4.56	4.4	14
SVR 55LCH	53	43.5	36.5	120	16×23×20	3060	214 164	312 239	6.35 5.95	30.8 28.8	4.35 6.49	28.0 24.5	6.73 5.99	6.5	14

Note *1 Pilot holes for side nipples are not drilled through in order to prevent foreign material from entering the product. THK will mount grease nipples per your request. Therefore, do not use the side nipple pilot holes for purposes other than mounting a grease nipple.

*2 The maximum length under "Length" indicates the standard maximum length of an LM rail.

*3 Static permissible moment: 1 block: Static permissible moment value with 1 LM block
Double blocks: Static permissible moment value with 2 blocks closely contacting with each other

Example of model number coding

SVR45 LCH 2 QZ TTHH C0 +1000L P T - II

1 2 3 4 5 6 7 8 9 10

1 Model number 2 Type of LM block 3 No. of LM blocks used on the same rail 4 With QZ Lubricator

5 Dust prevention accessory symbol (see page 25) 6 Radial clearance symbol (see page 7)

7 LM rail length (in mm) 8 Accuracy symbol (see page 8) 9 Symbol for LM rail jointed use 10 No. of rails used on the same plane

Note This model number indicates that an LM block and an LM rail constitute one set (i.e., the required number of sets when 2 rails are used in parallel is 2). Those models equipped with QZ Lubricator cannot have a grease nipple.

Standard Length and Maximum Length of the LM Rail

The table below shows the standard LM rail lengths and the maximum lengths of models SVR/SVS variations. If the maximum length of the desired LM rail exceeds them, connected rails will be used. Contact THK for details.

For the G dimension when a special length is required, we recommend selecting the corresponding G value from the table. The longer the G dimension is, the less stable the G area may become after installation, thus adversely affecting accuracy.

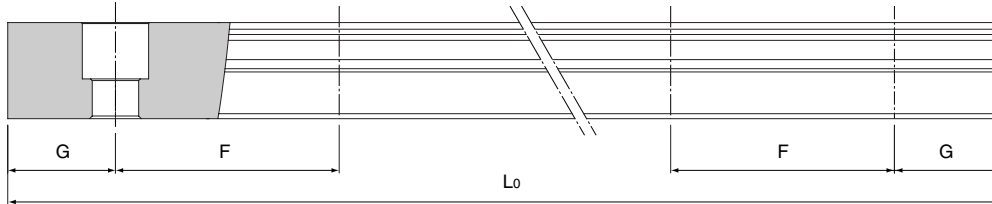

Standard Length and Maximum Length of the LM Rail for Models SVR/SVS

Unit: mm

Model No.	SVR/SVS 25	SVR/SVS 30	SVR/SVS 35	SVR/SVS 45	SVR/SVS 55	SVR/SVS 65
Standard LM rail length (L_0)	230	280	280	570	780	1270
	270	360	360	675	900	1570
	350	440	440	780	1020	2020
	390	520	520	885	1140	2620
	470	600	600	990	1260	
	510	680	680	1095	1380	
	590	760	760	1200	1500	
	630	840	840	1305	1620	
	710	920	920	1410	1740	
	750	1000	1000	1515	1860	
	830	1080	1080	1620	1980	
	950	1160	1160	1725	2100	
	990	1240	1240	1830	2220	
	1070	1320	1320	1935	2340	
	1110	1400	1400	2040	2460	
	1190	1480	1480	2145	2580	
	1230	1560	1560	2250	2700	
	1310	1640	1640	2355	2820	
	1350	1720	1720	2460	2940	
	1430	1800	1800	2565	3060	
	1470	1880	1880	2670		
	1550	1960	1960	2775		
	1590	2040	2040	2880		
	1710	2200	2200	2985		
	1830	2360	2360	3090		
	1950	2520	2520			
	2070	2680	2680			
2190	2840	2840				
2310	3000	3000				
2430						
2470						
Standard pitch F	40	80	80	105	120	150
G	15	20	20	22.5	30	35
Max length	2500	3000	3000	3090	3060	3000

Note 1: The maximum length varies with accuracy grades. Contact THK for details.

Note 2: If connected rails are not allowed and a greater length than the maximum values above is required, contact THK.

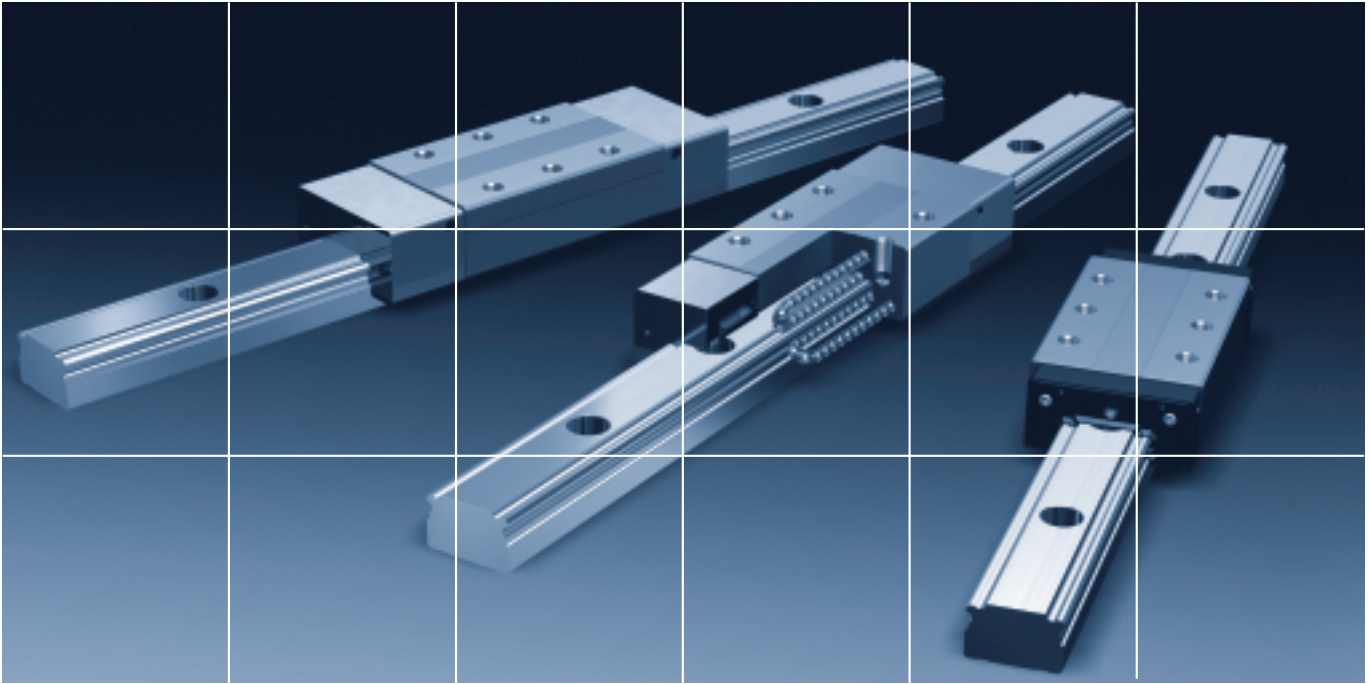

SVR/SVS OPTIONS

Options

For models SVR/SVS, dust-prevention and lubrication accessories are available. Make a selection according to the application and the installation site.

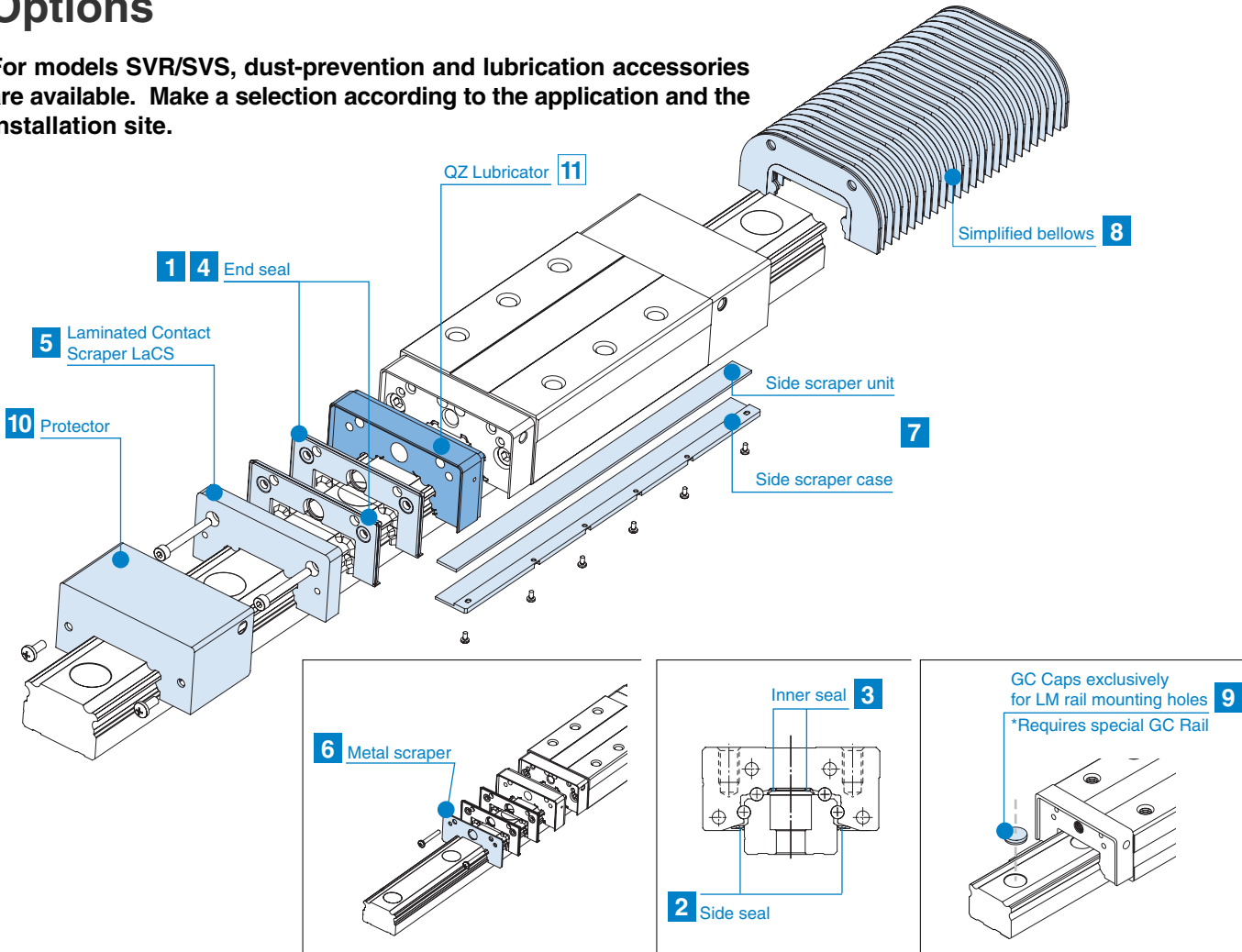

Dust Prevention Accessories

When foreign matter enters an LM system, it will cause abnormal wear or shorten the service life. It is necessary to prevent foreign matter from entering the system. Therefore, when possible entrance of foreign matter is predicted, it is important to select an effective sealing device or dust-prevention device that meets the working conditions.

1 End seal

Used in locations exposed to dust.

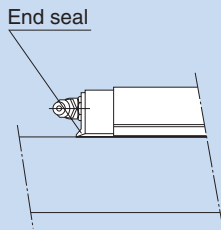

2 Side seal

Used in locations where dust may enter the LM block from the side or bottom surface, such as vertical, horizontal and inverted mount.

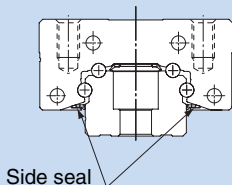

3 Inner seal

Used in locations severely exposed to dust or cutting chips.

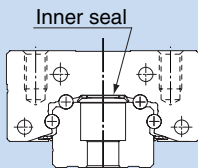

Seals and Scrapers

1 to 4 Seals

Highly wear-resistant end seals made of special resin rubber and side seals for increased dust-prevention effect are available.

If desiring a dust-prevention accessory, specify it with the corresponding symbol indicated in table 3.

For the supported LM Guide model numbers for dust-prevention accessories and the overall LM block length with a dust-prevention accessory attached (dimension L), see tables 4 and 5.

Seal resistance value

For the maximum seal resistance value per LM block when a lubricant is applied on seal SVR/SVS ... SS, refer to the corresponding value provided in table 1.

Table 1 Maximum Seal Resistance Value of Seal SVR/SVS ... SS Unit: N

Model No.	Maximum seal resistance
25	10
30	14
35	18
45	22
55	26
65	31

5 6 Scrapers

Laminated Contact Scraper LaCS®

For locations with an even more adverse working conditions, the Laminated Contact Scraper LaCS is available.

LaCS removes minute foreign matter adhering to the LM rail in multiple stages and prevents it from entering the LM block with a laminated contact structure (3-layer scraper).

Features

- Since the 3 layers of scrapers fully contact the LM rail, LaCS is highly capable of removing minute foreign matter.
- Since it uses oil-impregnated, foam synthetic rubber with a self-lubricating function, low friction resistance is achieved.

Table 2 Resistance of LaCS (for Reference) Unit: N

Model No.	Resistance of LaCS
25	8.1
30	13.4
35	15.5
45	23.3
55	28.6
65	39.6

Note 1: Each resistance value in the table only consists of that of LaCS, and does not include sliding resistances of seals and other accessories.

Note 2: For the maximum service speed of LaCS, contact THK.

Basic Specifications of LaCS

- Service temperature range of LaCS: -20°C to +80°C
- Resistance of LaCS (for Reference): indicated in table 2

*Note that LaCS is not sold alone.

Table 3 Symbols of Dust Prevention Accessories for Models SVR/SVS

Symbol	Dust prevention accessory
UU	With end seal
SS	With end seal + side seal + inner seal
DD	With double seals + side seal + inner seal
ZZ	With end seal + side seal + inner seal + metal scraper
KK	With double seals + side seal + inner seal + metal scraper
JJHH	With end seal + side seal + inner seal + LaCS + protector (serving also as metal scraper)
TTHH	With double seals + side seal + inner seal + LaCS + protector (serving also as metal scraper)
JJHHYY	With end seal + side seal + inner seal + LaCS + protector (serving also as metal scraper) + side scraper
TTHHYY	With double seals + side seal + inner seal + LaCS + protector (serving also as metal scraper) + side scraper

When Dust Prevention Accessories JJHH, TTHH, JJHHYY or TTHHYY are Attached

When dust prevention accessories JJHH, TTHH, JJHHYY or TTHHYY are attached, the grease nipple can be mounted in the location indicated in the figure below. The table below shows incremental dimensions with the grease nipple.

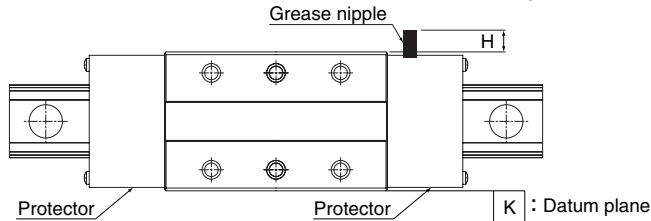

Note: When desiring the mounting location for the grease nipple other than the one indicated in the figure above, contact THK. Unit: mm

Model No.	Incremental dimension with grease nipple H	Nipple type	
SVR/SVS	25R/LR	5.5	PB1021B
	30R/LR	5.5	PB1021B
	35R/LR, RH/LRH	9	A-M6F
	45R/LR, RH/LRH	9	A-M6F
	55R/LR, RH/LRH	9	A-M6F
65R/LR	12	A-PT1/8	

For Models Attached with Contamination Protection Accessories UU or SS

For the mounting location of the grease nipple (N) and its incremental dimension (E) when contamination protection accessories UU or SS are attached, see the corresponding dimensional table (see page 11 to 22).

For Models Attached with Contamination Protection Accessories DD, ZZ or KK

For the mounting location of the grease nipple and its incremental dimension when contamination protection accessories DD, ZZ or KK are attached, contact THK.

When Dust Prevention Accessory HH is Attached

Types with accessory symbol HH (attached with LaCS) are attached with protectors.

Protector also serves as metal scraper.

For other types attached with a protector, contact THK.

Table 4 Overall LM Block Length (Dimension L) of Models SVR/SVS with a Dust Prevention Accessory Attached Unit: mm

Model No.	UU	SS	DD	ZZ	KK	JJHH	TTHH	JJHHYY	TTHHYY
25R/C	82.8	82.8	88	88.5	93.7	102.5	107.7	102.5	107.7
25LR/LC	102	102	107.2	107.7	112.9	121.7	126.9	121.7	126.9
30R/C	98	98	104.6	103.7	110.3	120.9	127.5	120.9	127.5
30LR/LC	120.5	120.5	127.1	126.2	132.8	143.4	150.0	143.4	150.0
35R/C	109.5	109.5	116.5	116.3	123.3	133.5	140.5	133.5	140.5
35LR/LC	135	135	142	141.8	148.8	159.0	166.0	159.0	166.0
45R/C	138.2	138.2	145.2	145.8	152.8	165.8	172.8	165.8	172.8
45LR/LC	171	171	178	178.6	185.6	198.6	205.6	198.6	205.6
55R/C	163.3	163.3	168.4	169.0	176.0	191.1	198.1	191.1	198.1
55LR/LC	200.5	200.5	205.6	206.2	213.2	228.3	235.3	228.3	235.3
65R/C	186	186	191.8	193.1	200.5	217.5	224.9	217.5	224.9
65LR/LC	246	246	251.8	253.1	260.5	277.5	284.9	277.5	284.9

Table 5 Overall LM Block Length (Dimension L) of Models SVR/SVS-H with a Dust Prevention Accessory Attached Unit: mm

Model No.	UU	SS	DD	ZZ	KK	JJHH	TTHH	JJHHYY	TTHHYY
35RH/CH	109.5	109.5	116.5	116.3	123.3	133.5	140.5	133.5	140.5
35LRH/LCH	135	135	142	141.8	148.8	159.0	166.0	159.0	166.0
45RH/CH	138.2	138.2	145.2	145.8	152.8	165.8	172.8	165.8	172.8
45LRH/LCH	171	171	178	178.6	185.6	198.6	205.6	198.6	205.6
55RH/CH	163.3	163.3	168.4	169.0	176.0	191.1	198.1	191.1	198.1
55LRH/LCH	200.5	200.5	205.6	206.2	213.2	228.3	235.3	228.3	235.3

Double seals

4

Used in locations exposed to much dust or many cutting chips.

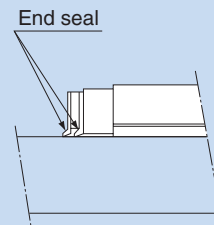

LaCS

5

Used in harsh environments exposed to foreign matter such as fine dust and liquids.

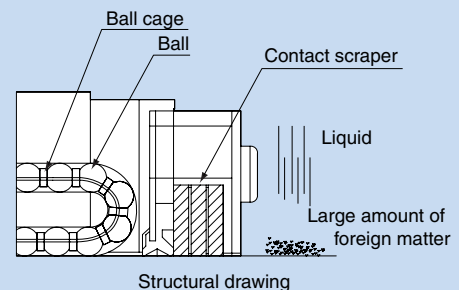

Metal scraper

6

Used in locations where welding spatter may adhere to the LM rail.

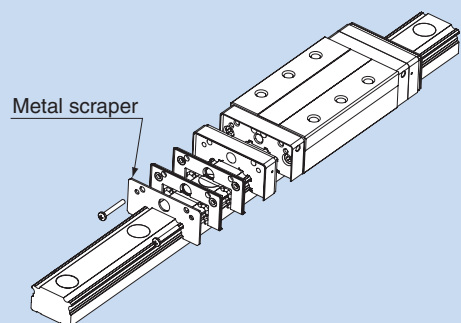

7 Side Scraper

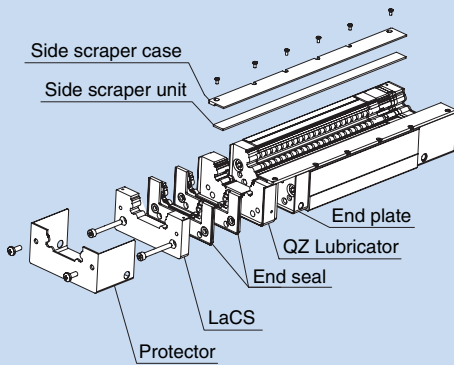

Side Scraper Configuration
(Options shown: QZTTHHYY)

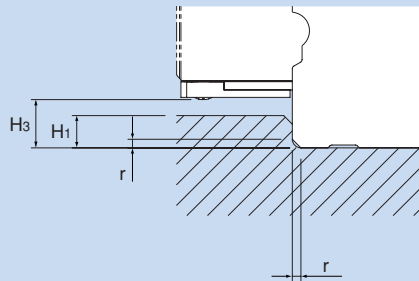

Side view of the LM block after the side scraper is mounted

7 Side Scraper

- Minimizes foreign material entering from the side of the LM Guide in a harsh environment.
- Demonstrates a dust protection effect in inverted or wall mount.

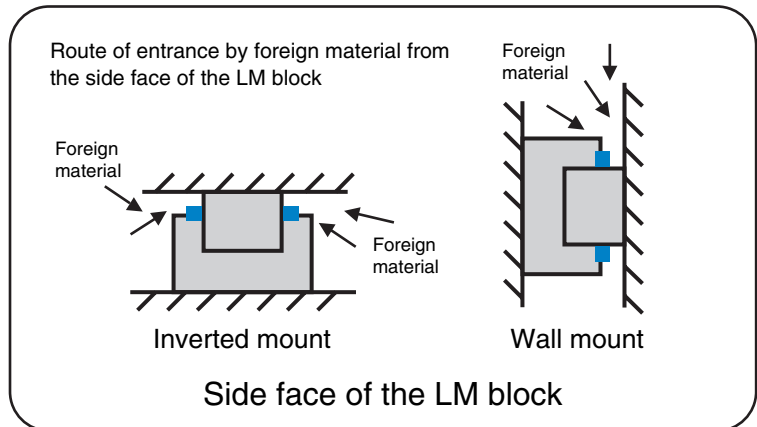

Note: The side scraper is not sold separately. Side scraper option need to be specified at the time of order.

The shoulder height of the mounting surface and the corner radius after the side scraper is mounted

Unit: mm

Model No.	Corner radius r (maximum)	Shoulder height of the LM rail section H ₁	H ₃
25	0.5	2	2.7
30	1	3.5	4.2
35	1	5.5	6.2
45	1	8	8.8
55	1.5	10.5	11.2
65	1.5	11	12.1

Maximum Resistance for the side scraper

Unit: N

Model No.	Maximum Resistance for the side scraper (TTHHYY Option)
25	4.4
25L	5.2
30	4.7
30L	5.5
35	4.6
35L	5.5
45	5.1
45L	6.1
55	5.3
55L	6.3
65	5.4
65L	6.9

Model number coding

SVR45 LR 1 QZ JJHH YY C1 +1200L



■ With a side scraper*

* Side scraper models SVR/SVS support various options of contamination-protection parts (P. 26) and lubrication-related parts (P. 30). Contact THK for details.

8 Simplified Bellows JSV

For Models SVR/SVS, simplified bellows JSV is available. Contact THK for details.

9 Metal Cap Dedicated for LM Rail Mounting Holes GC Cap

GC cap is a metallic cap that plugs the LM rail mounting hole (article compliant with the RoHS Directives). It prevents the entrance of foreign material and coolant from the LM rail top face (mounting hole) under harsh environments, and significantly increases the dust control performance of the LM Guide if used with a dust control seal.

Unit: mm

Model No.	Model No. for GC Cap	Outer diameter	Thickness H
SVR/SVS25	GC5	9.86	2.5
SVR/SVS30	GC6	11.36	2.5
SVR/SVS35	GC8	14.36	3.5
SVR/SVS45	GC12	20.36	4.6
SVR/SVS55	GC14	23.36	5.0
SVR/SVS65	GC16	26.36	5.0

If designating an LM Guide model attached with GC cap, observe the following example of model number coding.

Example of model number coding

SVR45 LR 2 QZ TTHH C0 + 1200L P - II GC

Model number	Type of LM block	With QZ Lubricator attached	No. of LM blocks used on the same rail	Symbol for contamination protection accessory	LM rail length (in mm)	Accuracy symbol	No. of LM rails used on the same plane ^{Note7}	Radial clearance symbol	With GC cap ^{Note7}
SVR45	LR	2	QZ	TTHH	C0	+ 1200L	P	- II	GC

Note 1: The LM rail of an LM Guide model attached with GC cap is of special type.

Note 2: GC cap cannot be mounted on an LM rail made of stainless steel or provided with surface treatment.

Note 3: If using the product in a special environment such as vacuum, low temperature or high temperature, contact THK.

Note 4: GC cap is not sold alone. It is always provided in combination with LM Guide.

Note 5: The mouth of the LM rail mounting hole is not chamfered. Take care not to hurt your hand when attaching GC cap.

Note 6: After attaching GC cap, be sure to level and clean (wipe off) the top face of the LM rail.

Note 7: If you desire a one-rail LM Guide model attached with GC cap, apply the following example of model number coding.

ex) SVR45LR2QZTTHHC0+1200LP GC With GC cap

*Add the symbol "GC" at the end of the model number.

For the C-cap, see the general catalog. For inquiries on other material (aluminum), contact THK

9 GC Cap

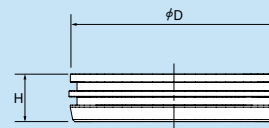

Mounting method

To insert GC cap into a mounting hole, use a flat metal piece like the one shown in the figure, and gradually drive the metal cap until its top is on the same level as the LM rail top face. When inserting GC cap, do not remove the LM block from the LM rail.

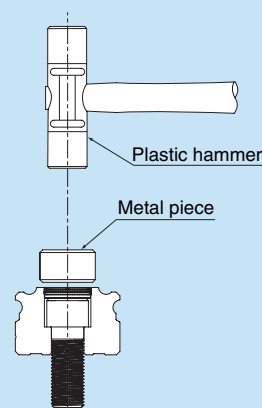

Plastic hammer

Metal piece

10 Protector

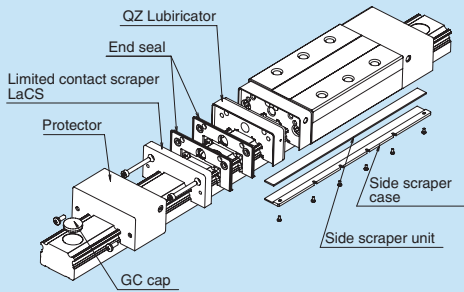

Protector Configuration
(Options shown: QZTTHYY)

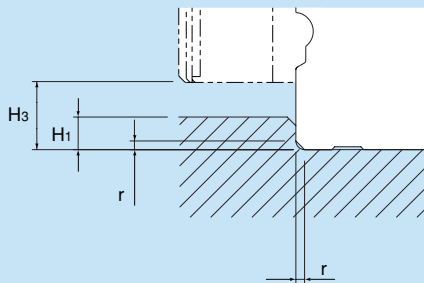

Side view of the LM block after the protector is mounted

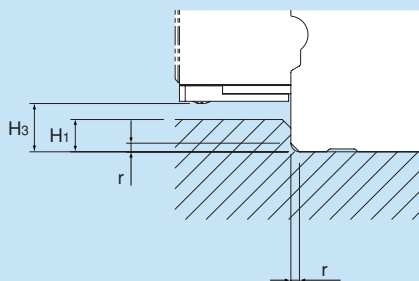

Side view of the LM block after the protector and side scraper are mounted

10 Protector

- The protector minimizes the entrance of foreign material even in harsh environments where foreign material such as fine particles and liquids are present.

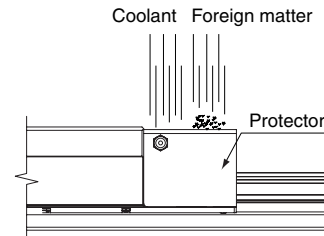

Configuration diagram of the inside the protector
(example: in case of QZJJHH type)

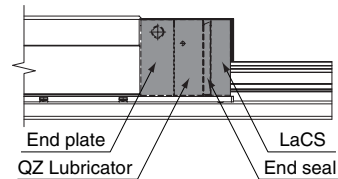

The shoulder height of the mounting surface and the corner radius after the protector is mounted

Unit: mm

Model No.	Corner radius r (maximum)	Shoulder height of the LM rail section H ₁	H ₃
25	0.5	4	5.5
30	1	5	7
35	1	6	9
45	1	8	11.6
55	1.5	10	14
65	1.5	10	15

The shoulder height of the mounting surface and the corner radius after the protector and side scraper are mounted

Unit: mm

Model No.	Corner radius r (maximum)	Shoulder height of the LM rail section H ₁	H ₃
25	0.5	2	2.7
30	1	3.5	4.2
35	1	5.5	6.2
45	1	8	8.8
55	1.5	10.5	11.2
65	1.5	11	12.1

*Contact THK if you want to use the Protector with other options.

Lubrication Accessories

11 QZ Lubricator™

The QZ Lubricator feeds the right amount of lubricant to the ball raceway on the LM rail. This allows an oil film to continuously be formed between the balls and the raceway, and drastically extends the lubrication and maintenance intervals.

When the QZ Lubricator is required, specify the desired type with the corresponding symbol indicated in table 6.

For supported LM Guide model numbers for the QZ Lubricator and the overall block length with the QZ Lubricator attached (L dimension), see tables 7 and 8.

Features

- Supplements lost oil to drastically extend the lubrication/maintenance interval.
- Eco-friendly lubrication system that does not contaminate the surrounding area since it feeds the right amount of lubricant to the ball raceway.
- The user can select a type of lubricant that meets the intended use.

Significant Extension of the Maintenance Interval

Attaching the QZ Lubricator helps extend the maintenance interval throughout the whole load range from the light-load area to the heavy-load area.

*Note that the QZ Lubricator is not sold alone.

*Those models equipped with the QZ Lubricator cannot have a grease nipple.

When desiring both the QZ Lubricator and a grease nipple to be attached, contact THK.

Table 6 Parts Symbols for Models SVR/SVS with the QZ Lubricator Attached

Symbol	Dust prevention accessories for LM Guide with QZ Lubricator attached
QZUU	With end seal + QZ Lubricator
QZSS	With end seal + side seal + inner seal + QZ Lubricator
QZDD	With double seals + side seal + inner seal + QZ Lubricator
QZZZ	With end seal + side seal + inner seal + metal scraper + QZ Lubricator
QZKK	With double seals + side seal + inner seal + metal scraper + QZ Lubricator
QZJJHH	With end seal + side seal + inner seal + LaCS + protector (serving also as metal scraper) + QZ Lubricator
QZTTTH	With double seals + side seal + inner seal + LaCS + protector (serving also as metal scraper) + QZ Lubricator
QZJJHHYY	With end seal + side seal + inner seal + LaCS + protector (serving also as metal scraper) + side scraper + QZ Lubricator
QZTTTHYY	With double seals + side seal + inner seal + LaCS + protector (serving also as metal scraper) + side scraper + QZ Lubricator

Table 7 Overall LM Block Length (Dimension L) of Models SVR/SVS with the QZ Lubricator Attached Unit: mm

Model No.	QZUU	QZSS	QZDD	QZZZ	QZKK	QZJJHH	QZTTTH	QZJJHHYY	QZTTTHYY
25R/C	102.8	102.8	108	108.5	113.7	122.5	127.7	122.5	127.7
25LR/LC	122	122	127.2	127.7	132.9	141.7	146.9	141.7	146.9
30R/C	118	118	124.6	123.7	130.3	140.9	147.5	140.9	147.5
30LR/LC	140.5	140.5	147.1	146.2	152.8	163.4	170.0	163.4	170.0
35R/C	139.5	139.5	146.5	146.3	153.3	163.5	170.5	163.5	170.5
35LR/LC	165	165	172	171.8	178.8	189.0	196.0	189.0	196.0
45R/C	168.2	168.2	175.2	175.8	182.8	195.8	202.8	195.8	202.8
45LR/LC	201	201	208	208.6	215.6	228.6	235.6	228.6	235.6
55R/C	201.4	201.4	208.4	209.0	216.0	231.1	238.1	231.1	238.1
55LR/LC	238.6	238.6	245.6	246.2	253.2	268.3	275.3	268.3	275.3
65R/C	224.4	224.4	231.8	233.1	240.5	257.5	264.9	257.5	264.9
65LR/LC	284.4	284.4	291.8	293.1	300.5	317.5	324.9	317.5	324.9

Table 8 Overall LM Block Length (Dimension L) of Models SVR/SVS-H with the QZ Lubricator Attached Unit: mm

Model No.	QZUU	QZSS	QZDD	QZZZ	QZKK	QZJJHH	QZTTTH	QZJJHHYY	QZTTTHYY
35RH/CH	139.5	139.5	146.5	146.3	153.3	163.5	170.5	163.5	170.5
35LRH/LCH	165	165	172	171.8	178.8	189.0	196.0	189.0	196.0
45RH/CH	168.2	168.2	175.2	175.8	182.8	195.8	202.8	195.8	202.8
45LRH/LCH	201	201	208	208.6	215.6	228.6	235.6	228.6	235.6
55RH/CH	201.4	201.4	208.4	209.0	216.0	231.1	238.1	231.1	238.1
55LRH/LCH	238.6	238.6	245.6	246.2	253.2	268.3	275.3	268.3	275.3

QZ Lubricator

11

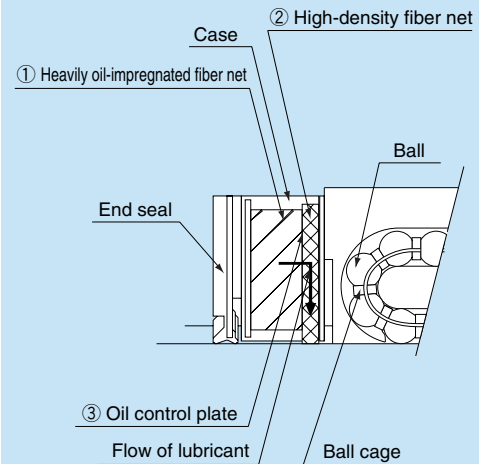

The structure of the QZ Lubricator consists of three major components:

- ① a heavy oil-impregnated fiber net (functions to store lubricant).
- ② a high-density fiber net (functions to apply lubricant to the raceway).
- ③ an oil-control plate (functions to adjust oil flow).

The lubricant contained in the QZ Lubricator is fed by the capillary phenomenon, which is used also in felt pens and many other products, as the fundamental principle.



Caged Ball LM Guide Models SVR/SVS



Precautions on use

● Handling

- This product consists mostly of heavy items (20 kg or more). When moving heavy items, use 2 or more people or moving equipment. This could cause injury or product damage.
- Do not disassemble the parts. This will cause dust to enter the product resulting in loss of functionality.
- Tilting an LM block or LM rail may cause them to fall by their own weight.
- Take care not to drop or strike the LM guide. This could cause injury or product damage. Giving an impact to it could also cause damage to its function even if the product looks intact.
- Prevent foreign material, such as dust or cutting chips, from entering the system. This could cause damage to ball circulation components and loss of functionality.
- When planning to use the LM system in an environment where the coolant penetrates the LM block, it may cause trouble to product functions depending on the type of the coolant. Contact THK for details.
- Do not use the product at temperature of 80°C or higher. Contact THK if you desire to use the product at a temperature of 80°C or higher.
- If foreign material such as dust or cutting chips adheres to the product, replenish the lubricant after cleaning the product with pure white kerosene. For available types of detergent, contact THK.
- If an LM guide will be in an inverted orientation, take preventive measures such as adding a safety mechanism to prevent falls. If the end plate is damaged due to an accident, etc., balls may fall out of the guide or the LM block become detached from the LM rail and fall down.
- When using the product in locations exposed to constant vibrations or in special environments such as clean rooms, vacuum and low/high temperature, contact THK in advance.
- When removing the LM block from the LM rail and then replacing the block, an LM block mounting/ removing jig that facilitates such installation is available. Contact THK for details.

● Lubrication

- Thoroughly remove anti-rust oil and feed lubricant before using the product.
- Do not mix lubricants of different physical properties.
- In locations exposed to constant vibrations or in special environments such as clean rooms, vacuum and low/high temperature, normal lubricants may not be used. Contact THK for details.
- When planning to use a special lubricant, contact THK before using it.
- When adopting oil lubrication, the lubricant may not be distributed throughout the LM system depending on the mounting orientation of the system. Contact THK for details.
- Lubrication interval varies according to the conditions. Contact THK for details.

● Storage

When storing the LM Guide, enclose it in a package designated by THK and store it in a horizontal orientation while avoiding high temperature, low temperature and high humidity.

● “LM GUIDE,” and “” are registered trademarks of THK CO., LTD.

- The photo may differ slightly in appearance from the actual product.
 - The appearance and specifications of the product are subject to change without notice. Contact THK before placing an order.
 - Although great care has been taken in the production of this catalog, THK will not take any responsibility for damage resulting from typographical errors or omissions.
 - For the export of our products or technologies and for the sale for exports, THK in principle complies with the foreign exchange law and the Foreign Exchange and Foreign Trade Control Law as well as other relevant laws.
- For export of THK products as single items, contact THK in advance.

All rights reserved

THK CO., LTD.

HEAD OFFICE 3-11-6, NISHI-GOTANDA, SHINAGAWA-KU, TOKYO 141-8503 JAPAN
INTERNATIONAL SALES DEPARTMENT PHONE:+81-3-5434-0351 FAX:+81-3-5434-0353

Global site : <http://www.thk.com/>

NORTH AMERICA

THK America, Inc.

● HEADQUARTERS

Phone:+1-847-310-1111 Fax:+1-847-310-1271

● CHICAGO OFFICE

Phone:+1-847-310-1111 Fax:+1-847-310-1182

● NORTH EAST OFFICE

Phone:+1-845-369-4035 Fax:+1-845-369-4909

● ATLANTA OFFICE

Phone:+1-770-840-7990 Fax:+1-770-840-7897

● LOS ANGELES OFFICE

Phone:+1-949-955-3145 Fax:+1-949-955-3149

● SAN FRANCISCO OFFICE

Phone:+1-925-455-8948 Fax:+1-925-455-8965

● DETROIT OFFICE

Phone:+1-248-858-9330 Fax:+1-248-858-9455

● TORONTO OFFICE

Phone:+1-905-820-7800 Fax:+1-905-820-7811

SOUTH AMERICA

THK Brasil LTDA

Phone:+55-11-3767-0100 Fax:+55-11-3767-0101

EUROPE

THK GmbH

● EUROPEAN HEADQUARTERS

Phone:+49-2102-7425-555 Fax:+49-2102-7425-556

● DUSSELDORF OFFICE

Phone:+49-2102-7425-0 Fax:+49-2102-7425-299

● FRANKFURT OFFICE

Phone:+49-2102-7425-650 Fax:+49-2102-7425-699

● STUTTGART OFFICE

Phone:+49-7150-9199-0 Fax:+49-7150-9199-888

● MUNICH OFFICE

Phone:+49-8937-0616-0 Fax:+49-8937-0616-26

● U.K. OFFICE

Phone:+44-1908-30-3050 Fax:+44-1908-30-3070

● ITALY MILAN OFFICE

Phone:+39-039-284-2079 Fax:+39-039-284-2527

● ITALY BOLOGNA OFFICE

Phone:+39-051-641-2211 Fax:+39-051-641-2230

● SWEDEN OFFICE

Phone:+46-8-445-7630 Fax:+46-8-445-7639

● AUSTRIA OFFICE

Phone:+43-7229-51400 Fax:+43-7229-51400-79

● SPAIN OFFICE

Phone:+34-93-652-5740 Fax:+34-93-652-5746

● TURKEY OFFICE

Phone:+90-216-362-4050 Fax:+90-216-569-7150

● PRAGUE OFFICE

Phone:+420-2-41025-100 Fax:+420-2-41025-199

● MOSCOW OFFICE

Phone:+7-495-649-80-47 Fax:+7-495-649-80-44

THK Europe B.V.

● EINDHOVEN OFFICE

Phone:+31-040-290-9500 Fax:+31-040-290-9599

THK France S.A.S.

Phone:+33-4-3749-1400 Fax:+33-4-3749-1401

CHINA

THK (CHINA) CO., LTD.

● HEADQUARTERS

Phone:+86-411-8733-7111 Fax:+86-411-8733-7000

● SHANGHAI OFFICE

Phone:+86-21-6219-3000 Fax:+86-21-6219-9890

● BEIJING OFFICE

Phone:+86-10-8441-7277 Fax:+86-10-6590-3557

● CHENGDU OFFICE

Phone:+86-28-8526-8025 Fax:+86-28-8525-6357

● GUANGZHOU OFFICE

Phone:+86-20-8523-8418 Fax:+86-20-3801-0456

● SHENZHEN OFFICE

Phone:+86-755-2642-9587 Fax:+86-755-2642-9604

THK (SHANGHAI) CO., LTD.

Phone:+86-21-6275-5280 Fax:+86-21-6219-9890

TAIWAN

THK TAIWAN CO., LTD.

● TAIPEI HEAD OFFICE

Phone:+886-2-2888-3818 Fax:+886-2-2888-3819

● TAICHUNG OFFICE

Phone:+886-4-2359-1505 Fax:+886-4-2359-1506

● TAINAN OFFICE

Phone:+886-6-289-7668 Fax:+886-6-289-7669

KOREA

SEOUL REPRESENTATIVE OFFICE

Phone:+82-2-3468-4351 Fax:+82-2-3468-4353

SINGAPORE

THK LM SYSTEM Pte. Ltd.

Phone:+65-6884-5500 Fax:+65-6884-5550

THAILAND

THK LM System Pte.Ltd.Representative Office in Thailand

Phone:+660-2751-3001 Fax:+660-2751-3003

INDIA

BANGALORE REPRESENTATIVE OFFICE

Phone:+91-80-2330-1524 Fax:+91-80-2330-1524

